



Jul 1st, 12:00 AM

Conceptual modelling of individual HRU's as a trade-off between bottom-up and top-down modelling, a case study.

R. Van den Bos

L. Hoffmann

J. Juilleret

P. Matgen

L. Pfister

Follow this and additional works at: <https://scholarsarchive.byu.edu/iemssconference>

Van den Bos, R.; Hoffmann, L.; Juilleret, J.; Matgen, P.; and Pfister, L., "Conceptual modelling of individual HRU's as a trade-off between bottom-up and top-down modelling, a case study." (2006). *International Congress on Environmental Modelling and Software*. 99.

<https://scholarsarchive.byu.edu/iemssconference/2006/all/99>

This Event is brought to you for free and open access by the Civil and Environmental Engineering at BYU ScholarsArchive. It has been accepted for inclusion in International Congress on Environmental Modelling and Software by an authorized administrator of BYU ScholarsArchive. For more information, please contact scholarsarchive@byu.edu, ellen_amatangelo@byu.edu.

Conceptual modelling of individual HRU's as a trade-off between bottom-up and top-down modelling, a case study.

R. van den Bos, L. Hoffmann, J. Juilleret, P. Matgen & L. Pfister

Department of Environment and Agro-Biotechnologies, Public Research Center-Gabriel Lippmann,

41 rue du Brill, L-4422 Belvaux, Grand-Duchy of Luxembourg

vandenbo@lippmann.lu

Abstract: Widely available geological and topographical maps contain a high level of potential information on the runoff behaviour on meso-scale (10-1000 km²). They can be used to identify major storage volumes or to estimate the reactivity of rainfall-runoff processes. Within this case study on the Alzette river basin in the Grand-Duchy of Luxembourg, basic characteristics like the location of sources, the spatial distribution of soils and a qualitative interpretation of the permeability of geological formations were used to roughly estimate the extension of hydrological similarly reacting areas (so-called Hydrological Response Units, HRU's). With discharge data of basins within or surrounding the area of interest, the runoff behaviour of the individual HRU's was verified and additionally identified runoff processes were added to eventually form parsimonious, conceptual model structures for each HRU. These model structures were evaluated through a Monte Carlo procedure on hourly discharge data of 8 representative basins, after which the parameters were calibrated and fixed. The resulting combined semi-distributed model was validated on discharge data of 10 other basins, with an average efficiency (R_{eff}) loss of 0.04, compared to an optimized reference model, and an acceptable mean R_{eff} of 0.79. This modelling approach only reproduces the general runoff behaviour of ungauged meso-scale basins within the region of interest and to less detail the specific behaviour of ungauged basins individually. In this respect, model uncertainty in the prediction can only be judged from the validation results, since model and parameter uncertainties are not easily transferable to ungauged basins. Application conditions for this approach are the availability of a number of discharge data sets and reasonable physio-geographical homogeneity in the study area.

Keywords: Conceptual Model; Hydrological Response Unit; Process Identification; Ungauged Basins

1. INTRODUCTION

Performing a well-balanced prediction in ungauged basins requires an optimal use of information sources about the runoff behaviour of these basins. The runoff behaviour of meso-scale basins (10-1000 km²) can be expected to have significant spatial variability, especially in hillslope hydrological processes. Scale of identification has a major impact on the identification of the various runoff regimes. As Blöschl and Sivapalan (1995) mention, the dominant runoff behaviour on meso-scale shows an integrated response of various small-scale runoff processes.

Two methodologies can be used to model this integrated runoff response. The first approach is

the bottom-up approach, which tries to identify each individual small-scale process and to combine them into one runoff signal, at the outlet of the basin. Unfortunately, not many sources of information are applicable for a consistent use on basin scale, to completely cover the information demand for this methodology. With local information comes uncertainty about spatial (and temporal) representation of the information. Beven (2001) states that, to use the micro-scale information, the model needs to be adapted to this scale as well, which invokes a parameterization problem at non-measured locations, due to the diversity and heterogeneity of the hillslope processes. The second methodology is the top-down approach, which tries to optimize the model structure through data-based mechanistic modelling (e.g. Young and Beven, 1994).

However, with ungauged basins, no data is available and the model prediction has to be transferred from other (surrounding) basins. Assumptions on the relation between these basins, in their turn, generate prediction uncertainties.

The methodology used in this paper tries to combine the advantages of both modelling approaches to optimize the process representation, in order to have a more robust transfer of the model concept on the ungauged basin. McDonnell (2003) positively advocated the use of knowledge about the first order controls on the runoff processes on basin scale as a good trade-off between experimental process knowledge and model complexity. Hence, hydrologically homogeneous meso-scale areas (known as HRU's) and their particular runoff regime have to be identified. Although this study is not the first to apply this method, in this attempt the model structure is adapted independently to each HRU, using a combination of hybrid bottom-up modelling (see Littlewood et al., 2003) and some top-down model optimization tools. In this respect, it is useful to have a new look on what kind of information is available on an applicable scale and how much this information tells us about the possible runoff regime of certain areas.

2. STUDY AREA

The study area is the Alzette river basin, which is mainly located in the Grand Duchy of Luxembourg, and has a dense measurement network of hourly discharge time series and rainfall data. A total number of 18 (sub)basins is used to represent the spatial and temporal runoff variations within the study area. Agricultural land (23.3%), grassland (30.7%) and forest (34.7%) are the dominating land use types, while urban areas, which are mainly concentrated in the south, cover 11.3% of the total basin area. The geology of the Alzette River basin is mainly characterized by Mesozoic deposits. Large marly plateaus with gentle slopes are interrupted by the steep slopes in the sandstone (of the cuesta front). The northern limit of the Alzette river basin is characterized by steep slopes and deep valleys in the schists of the neighbouring Ardennes massif, whereas in the southern part of the basin a limestone formation on top of the marls is present (Figure 1). Soil types are dominantly related to the geological formation (e.g. clayey soils on marls formations and sandy soils on sandstone formations). The alluvial formations are shallow and mainly located on marls. This short overview of the basin characteristics contains many indications on the possible HRU's that are to be identified.

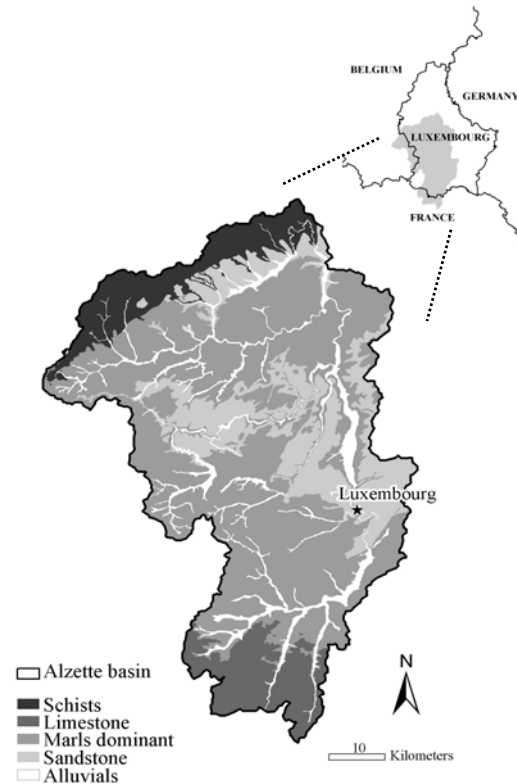

Figure 1. Generalized lithology of the Alzette river basin.

3. HRU IDENTIFICATION

A first distinction between areas is found in the permeability of the geological formations. Marls and schist formations are generally impermeable, whereas sandstones and limestone formations contain and transport relatively large volumes of water. Although soils can locally limit the infiltration to these reservoirs, these formations will give more gentle recession signals and permanent sources. These sources can be expected to be located downhill, which is verified by the topographical map. On the other hand, perennial sources uphill (often represented as dotted lines on the topographical map) indicate shallow sub-surface storage reservoirs and a relatively short runoff concentration time during and after rainfall events, which is the case for the marls and the schist formations.

Visiting the field helps to identify the distinctions between impermeable formations. On marls formations, significant surface runoff is visible during rainfall events. This is not the case for schist formations, which indicates a higher infiltration and/or storage capacity of the soils on schist. Combining this with the higher variability in steepness of the slope over the area, the runoff on schist formations results in a delayed and

transformed signal compared to marls formations. Since slopes are steep, little surface or subsurface storage can be expected. Marls formations are dominantly covered with agricultural land (approximately 70%) and surface water is rapidly collected in dense surface drainage systems. This invokes a highly reactive runoff regime for the marls formations. However, since slopes are gentle, some significant surface and sub-surface storage is possible. Some small lakes are present at the topographical map and some local drills indicated groundwater storage in the wide alluvial plains (see Figure 1).

The limestone formation has a different permeability than the sandstone formation. The calcareous identity and the presence of ancient mines force the water to be rapidly transported and stored in the large cracks and caverns. In sandstone formations a more general process of small crack and matrix flow is present. This makes the reactivity of the base flow reservoir higher for the limestone formation. A second difference is the runoff behaviour of the valleys. Although both formations have their valley on top of a marls formation, they are expected to give a different rainfall-runoff reaction. The valleys in the limestone area are highly urbanized (approximately 60%) and little infiltration is possible. In the sandstone valleys, on the other hand, the sedimentation of sand in the alluvial plain makes it possible for water to infiltrate and to be stored and the short-term runoff volume will be less. In Figure 2, the four units are visualized. This visualization is the first step towards an understanding of the first order controls on the hydrological processes where the arrows indicate the monitored main flowpaths of the water.

4. CONCEPTUALIZATION OF THE HRU'S

4.1 Hybrid bottom-up conceptualization

Each HRU needs to be represented by a simple, but effective conceptual structure, which captures the described process behaviour. An initial model structure is made out of a Production Reservoir (PR) and a Transformation Reservoir (TR), representing the soil and land surface interception and the reactivity of the runoff processes, respectively. The PR has a maximum capacity, PR_{max} , beyond which additional rainfall input becomes runoff water. An evapotranspiration limitation, lp , is built in to transform estimated potential evapotranspiration into actual evapotranspiration (AET). Below the lp -value the evapotranspiration is linearly limited with the relative reservoir level, similar to the HBV-model (Bergström, 1995). The TR consists of a single linear reservoir with a reservoir constant, k , determining the residence time of the runoff water. Following, this structure is adapted to the specific runoff behaviour of the HRU's.

Within the HRU of marls a linear reservoir is added, with a reservoir constant, k_{RI} , causing a relatively long residence time, to represent the monitored surface storage, which intercepts a (constant) part, RI , of the runoff. The HRU of schist is extended through a delay function, transforming the output signal of the PR into a delayed triangular-shaped input signal of the TR to better represent delay in the sub-surface runoff processes (similar to the MAXBAS function in the HBV-model). Within the HRU of sandstone, a

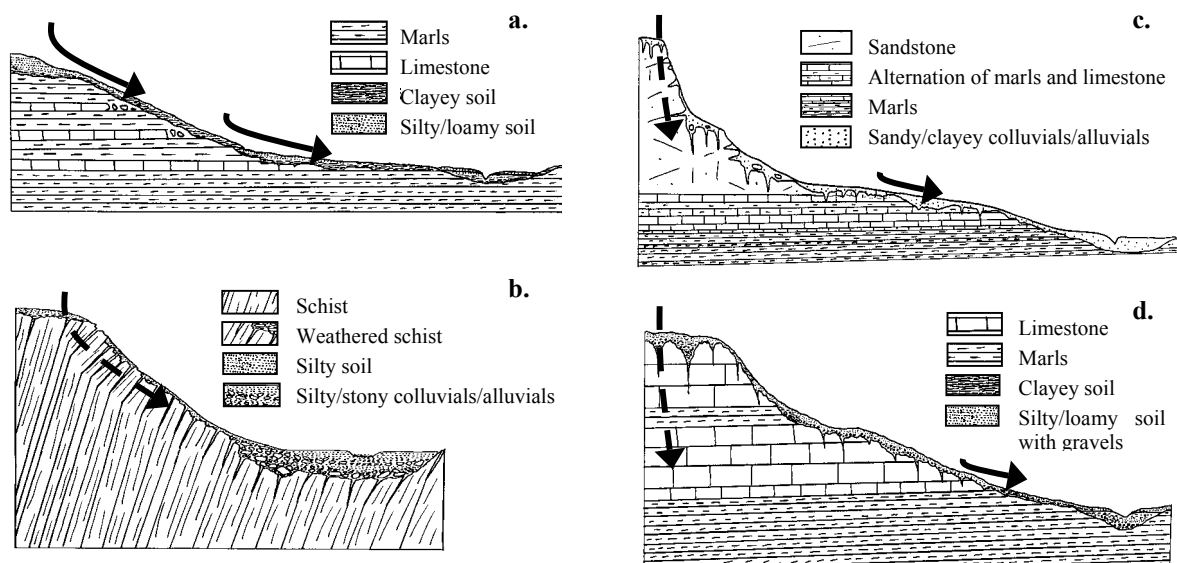

Figure 2. General structure of each lithology and their main water flowpaths for (a) the marls unit, (b) the schist unit, (c) the sandstone unit and (d) the limestone unit.

valley structure was added with an independent PR and TR. The rain contribution to both structures is defined through a constant fraction of the rainfall, *val*. Nothing has been added to the HRU of limestone, except a description of the runoff from urbanized areas. However, it is chosen to bypass the effect of urbanization in such a way that this process is not HRU, but basin related. The part of the rainfall turning into urban runoff is determined through a linear relation with the urbanization ratio of the basin, *UR*, and the transformation of urban runoff is accomplished with a linear reservoir with an *a priori* estimated reservoir constant of 0.5 (h⁻¹).

4.2 Top-down model analysis

The parameters of each HRU are calibrated on two basins, the smallest and the largest basin available for each lithological substratum, using a large number of Monte Carlo runs. For each HRU, the output signal is recalculated according to its areal fraction inside the basin of interest, after which these individual signals are combined into one runoff signal at the outlet of the basin. The objective function, used in this study, is the Nash-Sutcliffe efficiency (R_{eff}), which well represents the general dynamics of the runoff behaviour.

To eliminate the impact of basin size on the model parameters, an additional model structure is added to the total structure to represent the routing of the hydrograph. This routing module is estimated *a priori* through analysis of the hydrograph propagation within different river sections throughout the Alzette river basin. Using the principles of a cascade (i.e. series) of linear reservoirs with hourly time steps, the results turned out to be reasonably consistent with a mean reservoir constant of 0.43 (h⁻¹) for a river section of 6.8 km. Although the runoff of the HRU's and the direct runoff from urban areas are calculated on a lumped scale, their outputs are redistributed, according to their areal fraction, over the river sections of the routing module.

Next, the performance of each HRU individually has been evaluated. It appeared that the hydrograph of relatively fast reacting areas could not be captured with a single linear reservoir constant. A non-linearity factor was added to overcome this problem, which is represented by:

$$k^{TFM}(t) = k_0 / \{1 - \exp[-\alpha / TR(t)]\} \quad (1)$$

where k_0 is a basic reservoir constant and α the non-linearity factor. TFM stands for the Transmissivity Feedback Mechanism, which means a non-linearly increasing flow capacity of the medium under growing saturation levels (see

Bishop et al., 2004). It is based on sub-surface runoff processes, but the same effect accounts for shallow surface runoff processes. The next adaptation is made in the HRU of schist where a significant runoff volume was present under non-saturated PR conditions. This runoff is generated through bypass flow in the macropores of the soil, surpassing the interception capacity of the soil. The schist area is mainly forested and connected macropore systems, created by roots and cracks, can transport significant volumes within the shallow soil. Hence, a part of the rainfall, *macro*, which is linearly related to the storage level of the PR, directly flows into the delayed runoff process.

Next step in the top-down evaluation procedure is the parameter sensitivity and correlation analysis in relation to the chosen objective function. Parameters, which represent first order processes, have to show a high sensitivity towards R_{eff} , whereas low sensitivity towards R_{eff} indicates process conceptualization errors or processes with second- or lower-order control on the runoff behaviour of the HRU. These redundant model components can be replaced by constant values or different structures. Inspection of parameter sensitivity is done with a modified version of the Regionalized Sensitivity Analysis (RSA, Freer et al., 1996). It appeared that significant parameter sensitivity was present in the RSA plots of all calibration basins and no redundancy in the model structures was found.

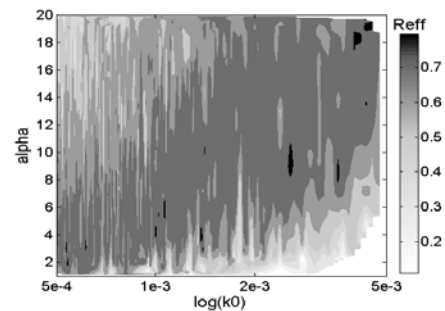

Figure 3. Parameter correlation surface plot for the two parameters of the TFM component for the HRU of schist (Maisbich basin)

Parameter correlation could also indicate redundant parameters, where two parameters can be replaced by one as long as the overall performance is not affected. Removing the influence of one parameter increases the sensitivity of the other parameter to better identify its optimum value. Parameter correlation can be visualized by plotting them against each other with the range of performance values for R_{eff} indicated in different colours. The example of Figure 3 shows an obvious correlation between parameters $k_{0,schist}$ and α_{schist} . The same type of correlation

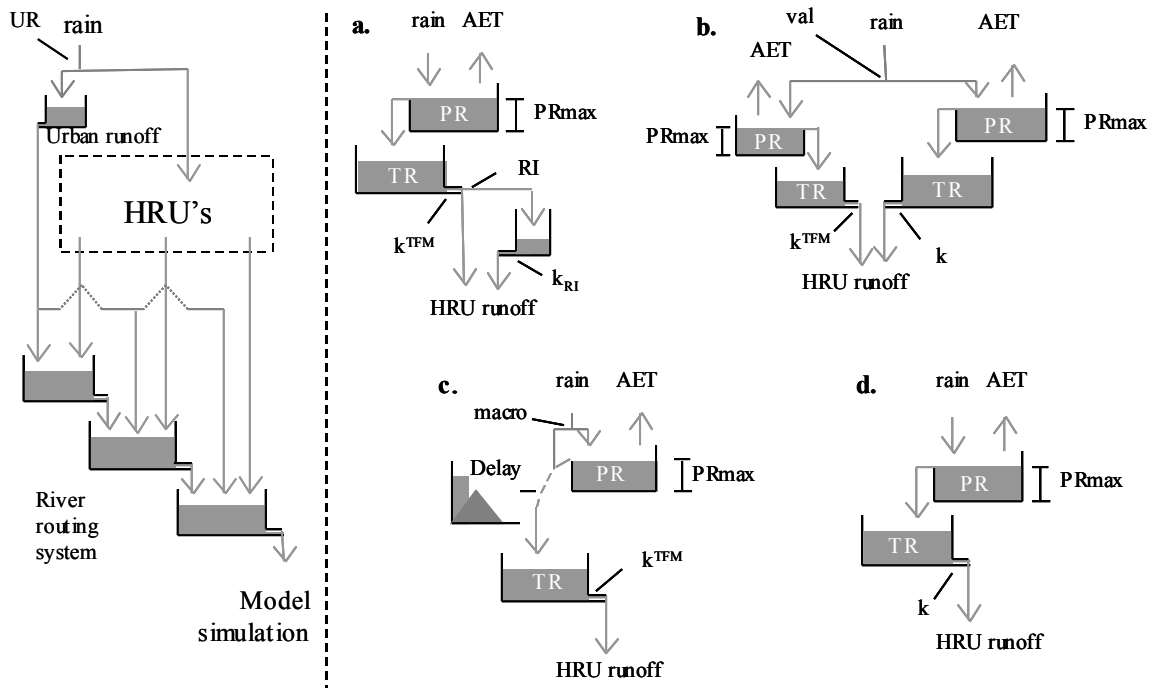

Figure 4. The general model structure and the HRU model structure of (a) marls, (b) sandstone, (c) schist and (d) limestone. The parameters are explained in detail in section 4.1 and 4.2.

between k_0 and α were found in all other HRU's, because of their presence in the same process description (TFM). Replacing k_0 by a constant value of $0.002 \text{ (h}^{-1}\text{)}$, according to the low sensitivity around this value for all basins, did not affect the performance of the model. The same is done with the correlated parameters lp and $PRmax$, whereby lp received a constant value of 0.4 (-) . The eventual four HRU's are visualized in Figure 4 together with the general model structure, with a complete overview of all the described parameters.

5. REGIONAL MODEL PERFORMANCE

Out of the two calibration basins of each HRU a single regional parameter set is calibrated, taking the best-fit of the sum of R_{eff} for the two basins out of the Monte Carlo procedure. The model structures with the fixed parameters are validated against ten meso-scale sub-basins. Additionally, the model performance of the HBV-model for each basin is used as a reference value to be able to evaluate the performance of the developed model. The HBV-model is known to perform well on meso-scale basins. Table 1 gives the results of the calibration and the validation procedure.

The importance of parameter uncertainty is not very high, due to the basin transfer process, since the parameter optimization procedure is not

performed on the eventual basin of interest. Therefore a reference model, which is optimized against the validation basins, tells more about the accuracy of the model performance. In this study, an overall efficiency 'loss' of 0.04 for the R_{eff} and no clear failure of the model performance is found, which is a good indication of the stability of the model prediction. However, more detailed uncertainty analysis is needed to enhance the practical applicability of the model.

Besides the overall model performance, also the individual HRU performance can be evaluated from table 1. Some discrepancy in the performance of the individual HRU's is found. The HRU of schist and marls performs the best, however, due to the fast runoff reaction of the marls areas, some small-scale basins suffer from a timing inaccuracy due to the absence of a rain gauge station in the near surrounding. Some problems exist in the small-scale performance of the HRU of sandstone, where the description of the processes is too general, compared to their spatial variability within this basin. Hence, the model can only be applied on a larger scale for this HRU. The HRU of limestone performs reasonably well, knowing that this HRU contains only two parameters. However, applicability on a smaller scale is expected to have a lower performance, due to the same problem of small-scale spatial variability, because the behaviour is similar to that of the sandstone areas.

This problem does not occur in the more homogeneous hillslope-runoff reaction of the marls and schist areas.

Table 1. R_{eff} results for the calibration and validation basins, with HRU indicating a significant part of the basin being sandstone (SS), schist (SC), marls (MA) or limestone (LS).

Basin (km ²)	HRU	at-site	regional	HBV
Huewel. (2.7)	SS	0.72	0.70	0.67
Eisch (161)	SS	0.86	0.84	0.90
Maisb. (1.2)	SC	0.84	0.82	0.85
Wiltz (103)	SC	0.87	0.87	0.86
Mierb. (6.7)	MA	0.78	0.74	0.80
Eisch (49)	MA	0.81	0.78	0.82
Alzette (51)	LS	0.78	0.77	0.67
Alzette (225)	LS	0.80	0.78	0.80
Calibration average		0.81	0.79	0.80
Mamer (82)	SS	0.80	0.79	0.81
Colpach (20)	SC	0.87	0.83	0.84
Mamer (18)	MA	0.73	0.72	0.75
Petrusse (45)	MA	0.77	0.74	0.76
Schweb. (30)	MA	0.83	0.80	0.84
Dudel. (46)	LS	0.79	0.74	0.78
Attert (160)	-	-	0.80	0.87
Attert (246)	-	-	0.87	0.91
Alzette (285)	-	-	0.81	0.86
Alzette (1078)	-	-	0.83	0.88
Validation average			0.79	0.83

6. CONCLUSIONS

Combining process knowledge, generated from basic information sources, and some model evaluation tools created a robust description of the meso-scale processes within the Alzette River basin. Although bottom-up process descriptions are in general somewhat subjective, top-down evaluation tools and improvements in model performance enhance the reliability of the chosen model structure. Moreover, top-down approaches, applied in a more analytic than deterministic way, retain the direct relation between the model structure and the meso-scale process controls, identified in the bottom-up analysis. In this case, model simplicity is the key word, knowing that a higher model complexity is not supported by the amount of data that is available.

The methodology is only applicable on a meso-scale, since small-scale hydrological processes can

be very heterogeneous. It is at the meso-scale where the integrated response of these processes can be identified. Hence, the first order controls on the runoff, which have been represented by the parameters in the model, are also applicable at this scale only.

7. ACKNOWLEDGEMENTS

This study was part of the CYCLEAU and the CLIMAT project, financed by the National Research Fund (FNR) of the Grand Duchy of Luxembourg. Many thanks are given to Mr. Kipgen from the Administration de la Gestion de l'Eau and Mr. Schleich from the Administration des Services de Secours, both affiliated to the Ministry of Interior, for providing a part of the rainfall and discharge data series.

8. REFERENCES

- Bergström, S., The HBV model. In: Computer Models of Watershed Hydrology (Ed. by V.P. Singh), Water Resources Publications, 443 pp., Highlands Ranch, Colorado, USA, 1995.
- Beven, K.J., How far can we go in distributed hydrological modelling? *Hydrology and Earth System Sciences*, 5(1), 157-172, 2001.
- Bishop, K., J. Seibert, S. Köhler and H. Laudon, Resolving the Double Paradox of rapidly mobilized old water with highly variable responses in runoff chemistry, *Hydrological Processes*, 18(1), 185-189, 2004.
- Blöschl, G. and M. Sivapalan, Scale issues in hydrological modelling: A review. In: Scale Issues in Hydrological Modelling (Ed. by J.D. Kalma, and M. Sivapalan), John Wiley & Sons, 9 pp., Chichester, UK, 1995.
- Freer, J., K.J. Beven and B. Ambroise, Bayesian estimation of uncertainty in runoff prediction and the value of data: An application of the GLUE approach. *Water Resources Research*, 32(7), 2161-2173, 1996.
- Littlewood, I.G., B.F.W. Croke, A.J. Jakeman and M. Sivapalan, The role of 'top-down' modelling for Prediction in Ungauged Basins (PUB), *Hydrological Processes*, 17(8), 1673-1679, 2003.
- McDonnell, J.J., Where does water go when it rains? Moving beyond the variable source area concept of rainfall-runoff response, *Hydrological Processes*, 17(9), 1869-1875, 2003.
- Young, P.C. and K.J. Beven, Data-Based Mechanistic modelling and the rainfall-flow non-linearity, *Environmetrics*, 5, 335-363, 1994.