



All Faculty Publications

2007-01-01

Solar Dryer Construction and Use Manual Version 2.0 2007

Jonathan P. Rowe
rowe.jp@gmail.com

Jonathan K. Russon
jonathan.trish@gmail.com

See next page for additional authors

Follow this and additional works at: <https://scholarsarchive.byu.edu/facpub>

 Part of the [Food Science Commons](#), and the [Nutrition Commons](#)

Original Publication Citation

Department of Nutrition, Dietetics, and Food Science Brigham Young University

BYU ScholarsArchive Citation

Rowe, Jonathan P.; Russon, Jonathan K.; and Steele, Frost M., "Solar Dryer Construction and Use Manual Version 2.0 2007" (2007).
All Faculty Publications. 938.

<https://scholarsarchive.byu.edu/facpub/938>

This Peer-Reviewed Article is brought to you for free and open access by BYU ScholarsArchive. It has been accepted for inclusion in All Faculty Publications by an authorized administrator of BYU ScholarsArchive. For more information, please contact scholarsarchive@byu.edu, ellen_amatangelo@byu.edu.

Authors

Jonathan P. Rowe, Jonathan K. Russon, and Frost M. Steele

Solar Dryer Construction and Use Manual

Version 2.0 2007

Jonathan P. Rowe, Jonathan K. Russon, Frost M Steele
Department of Nutrition, Dietetics, and Food Science
Brigham Young University
Provo, Utah, 84602
USA

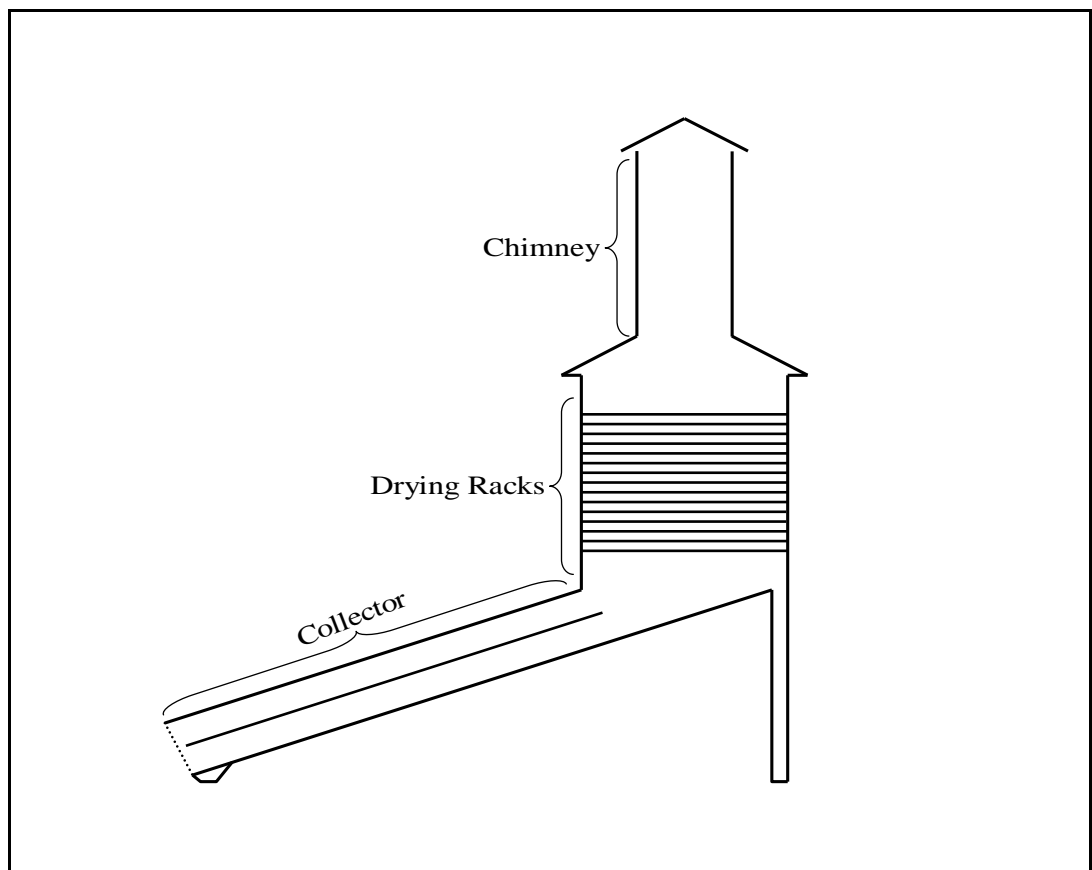

Introduction—

In less time than it took to develop this solar dryer and manual, the Pacific Island area has experienced several typhoons and tropical depressions followed by significant flooding and destruction of homes, properties and crops. It is in the interest of all people to become more self-reliant in times of need and to have the basic necessities available at a moment's notice to sustain life until transportation, commerce, health care, agriculture, water, etc. can be restored to a more normal state. This work was done to enable the people of the Pacific islands to meet some of their food requirements in times of need by enabling them to preserve some of their indigenous crops for storage in times of emergency.

This manual is developed for the use of those interested in drying of food products in the Pacific Island areas. The dryer was developed for use in the Pacific area, but can easily be adapted for use in most any area of the world. The angle of the solar panel area to the sun is set for use in areas close to the equator. The angle could be adjusted relative to the latitude of the area and season of the year in which you wish to dry food products, but little would be gained by this minor adjustment and so the angle used in this plan should be satisfactory to most areas of the world.

In the development of this solar dryer, consideration was taken to use only materials that should be readily available in most island areas. Cost of materials was also considered with the cost of this dryer being approximately \$180-\$200 US as purchased in Fiji. Naturally this will vary from time to time and from location to location. This value is given only as an estimate. While every effort was made to minimize the cost of the dryer, it must be realized that this dryer was developed for use by groups and therefore is more costly than the average family could afford, but several families together should be able to construct a dryer without significant financial burden.

Some carpentry skills are necessary for successful construction of the dryer. This manual is developed for those with minimal carpentry skills. If there are questions on methods used, please refer to a carpenter.

Comments and feedback regarding this manual, procedures, and application can be directed via email to Dr. Frost Steele at frost_steele@byu.edu

Solar Dryer Materials List

Quantity	Dimensions	Description	Metric measures
1	*8'x 4'x 3/4"	Exterior Plywood sheet	2.4m x 1.2m x 19mm
1	**8' x 4' x 1/4"	Exterior Plywood sheet	2.4m x 1.2m x 6mm
2	8' x 4" x 2"	treated pine lumber, dressed	100mm x 50mm
20	8' x 2" x 1"	treated pine lumber, dressed	50mm x 25mm
3	3/8" x 6'	Dowel	9.5mm x 1.8m
1 liter		black exterior paint semigloss	
1 kg	1"	galvanized jolt head nails	
1	200 ml	wood glue	
2 pair	4"	strap hinges, light duty	100mm
2 cans	10 oz	flat black spray paint	
2	3"	gate hook brass or galvanized	
1 tube	300 g	silicone adhesive and sealant	
2 meter	1/8" link	galvanized chain	
6 meters	3' width	23ga welded 1/2" mesh galvanized	915mm width
10 meters	20ga	galvanized steel wire	
1	6' x 2' x 1/8"	Clear Pespex (plexiglass)	1.83mx610mmx3mm
1 kg	1 1/4"	Wood screws (gib board screws work well)	
1/2 kg	2"	Wood screws (gib board screws work well)	
7 meters	30 cm width	Heavy Grade Aluminum Foil	

Tools Required

Tape rule

Pencil

Electric circular saw, hand saw may be used as well

Electric drill with bits, hand drill may be used as well

Hammer

Safety glasses

Heavy duty scissors

Screwdrivers

Wire cutters

Not absolutely necessary, but helpful

4 rubber caster wheels (2") mounted at the base of the dryer to aid in movement of the dryer. Locking casters are recommended.

Table saw

Level

Carpenter square

Protractor or carpenters triangle

*Can use 1/2" in place of 3/4" plywood, but strength and durability will be less

**Can use 4mm in place of 6mm, but strength and durability will be less

Procedure for dryer body assembly

- 1- Assemble **all** building materials and tools before beginning.
- 2- Lay out dryer pieces on 19 mm exterior plywood according to dimensions from layout plan below.

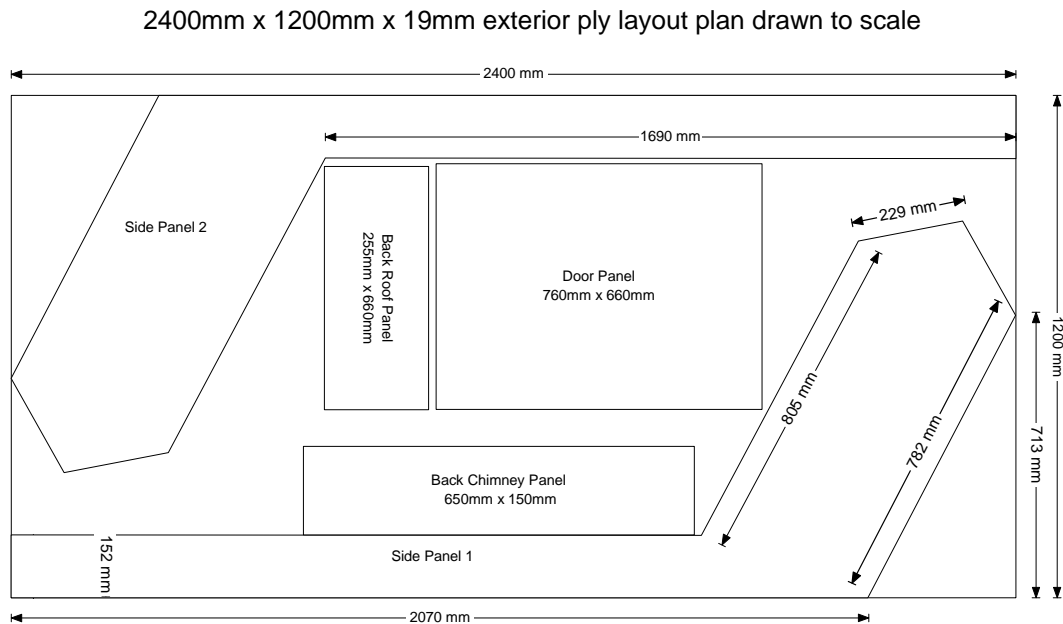

Side panel detail measurements (mm)
(not to scale)

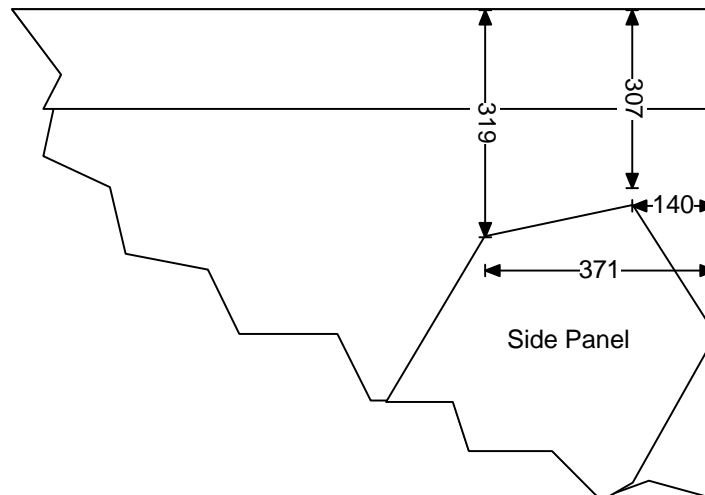

- 3- Cut out **only** side panel 1 from 19mm sheet being careful not to cut into other pieces.
- 4- Flip side panel 1 onto side panel 2 to ensure they are matching mirror images. Make any necessary adjustments to side panel 2.

- 5- Cut out side panel 2 from 19 mm sheet, again be careful not to cut into remaining pieces.
- 6- Cut out door panel and roof panel and chimney panel from 19mm sheet.
- 7- Lay out dryer pieces on 6mm exterior plywood according to Figure 2, ensuring that all pieces fit as described.

Figure 2-
2400mm x 1200mm x 6mm exterior ply layout plan -drawn to scale

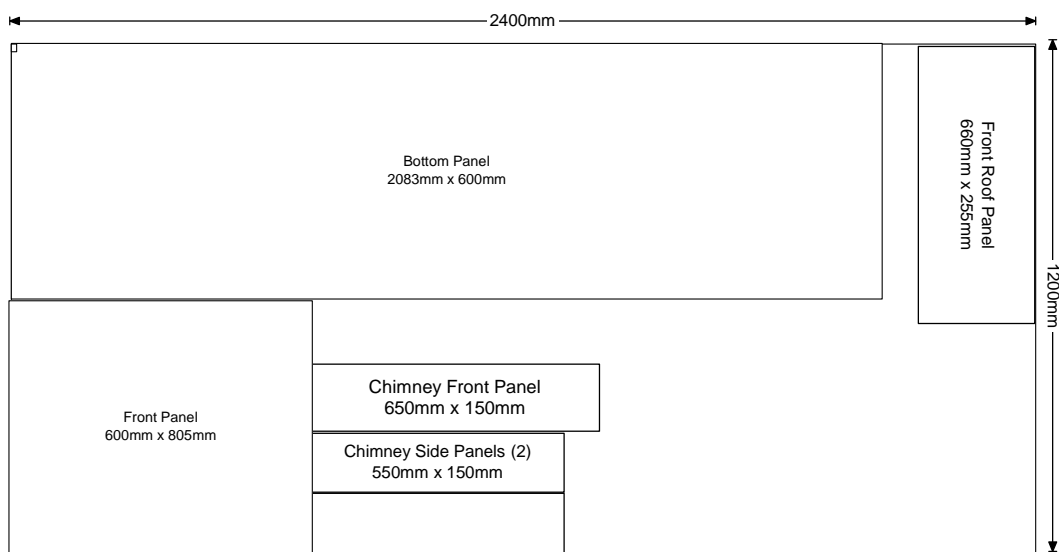

- 8- Cut a 255mm piece of wood off the end of the 6mm sheet this will later be cut into the front roof panel.
- 9- Cut the remaining 6mm piece exactly in half lengthwise. From these pieces the bottom panel, front panel, and chimney pieces will be constructed. This cut down the middle must be exact so the two pieces are of equal width.
- 10- Measure and cut the bottom panel followed by the front panel and then the chimney panels.

11-Glue and nail bottom panel to side panels as shown below. Bottom panel should be flush at the top leaving approximately 20mm overhang at the bottom.

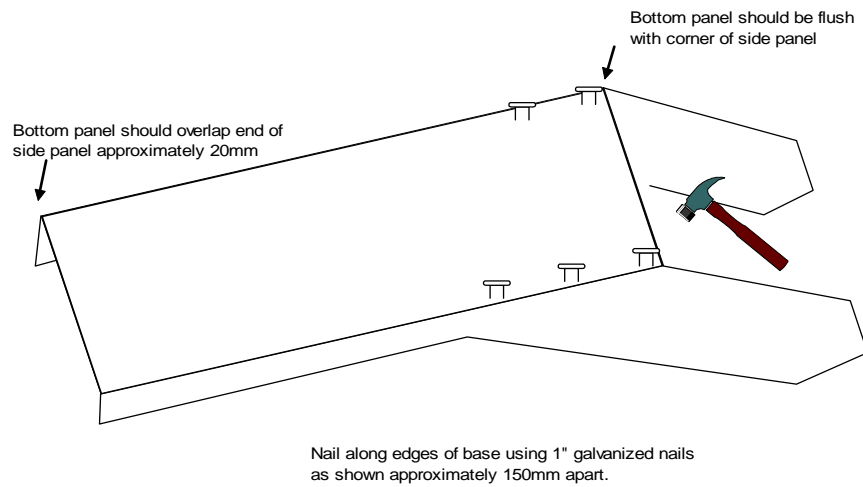

12-Cut 10 struts from 50mm x 25mm pine 561mm in length.

13-Attach struts connecting side panels using glue and two 2" wood screws in locations as shown below.

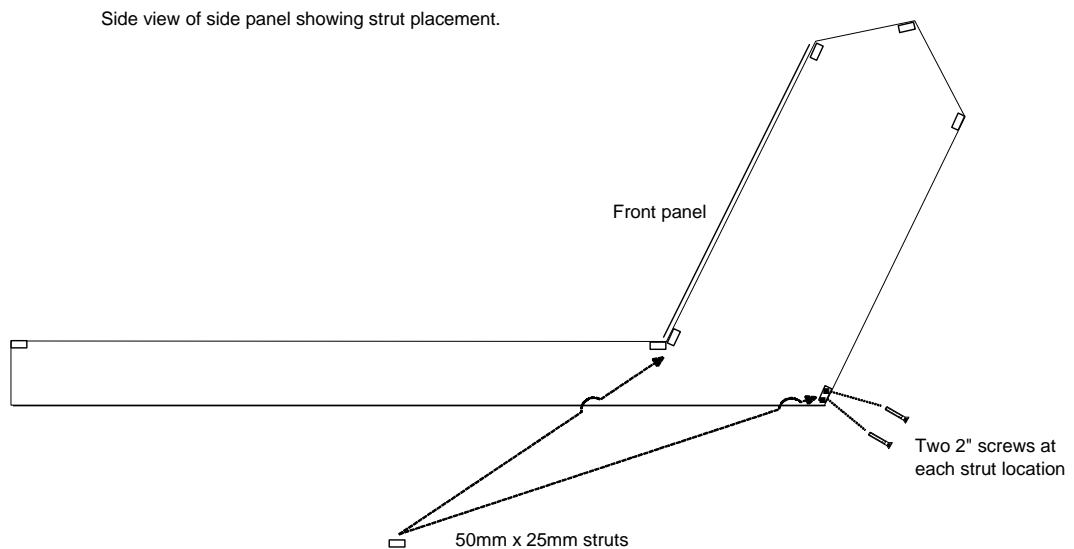

14-Attach front panel as shown above using 1 1/4" wood screws at 200mm spacing.

15-Cut a length of 100mm x 50 mm pine 610mm in length and attach to bottom front of dryer using 4- 2" screws as shown below for front base of dryer.

16-With the help of another, place the dryer body against a straight wall so the back of the dryer housing is flush to the wall as shown. Place each of the 100mm x 50mm pine timbers on each side of the dryer and also flush with the wall as shown. With a pencil, mark the angles of the dryer on the timber as shown.

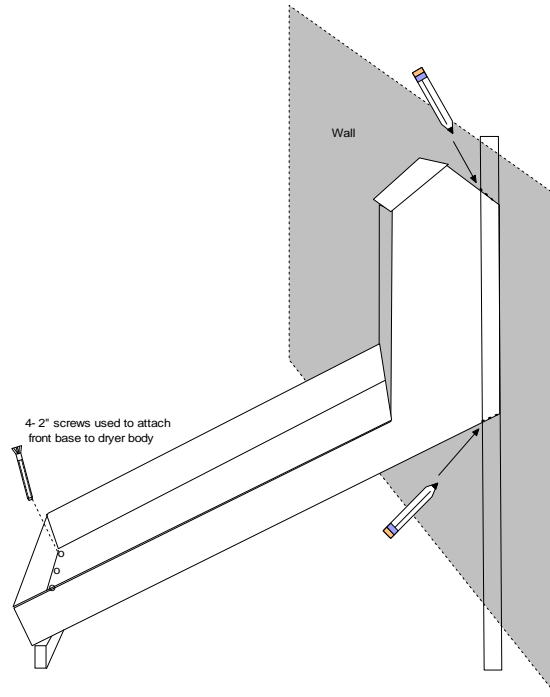

17-With each of the marked 100mm x 50mm timbers cut the top off at the angle marked. **Do not cut the bottom angle completely through!** Cut the inside of the timber halfway through at the bottom marked angle as shown below to a depth of 20mm. Then rip the timber to the top as shown, cutting out the piece shaded to form the dryer legs.

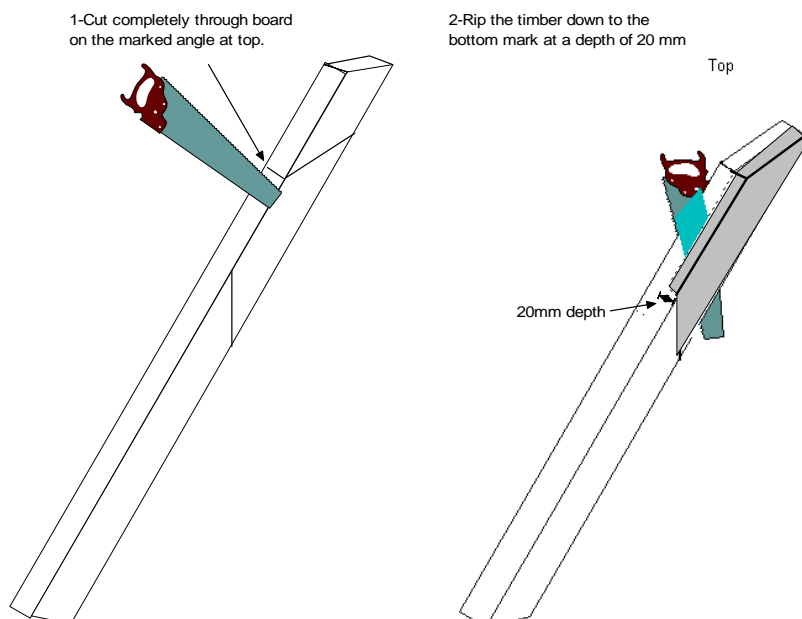

18-Attach dryer legs to dryer body, resting the dryer on the notched support of the leg. Attach with 2" screws as shown in next diagram.

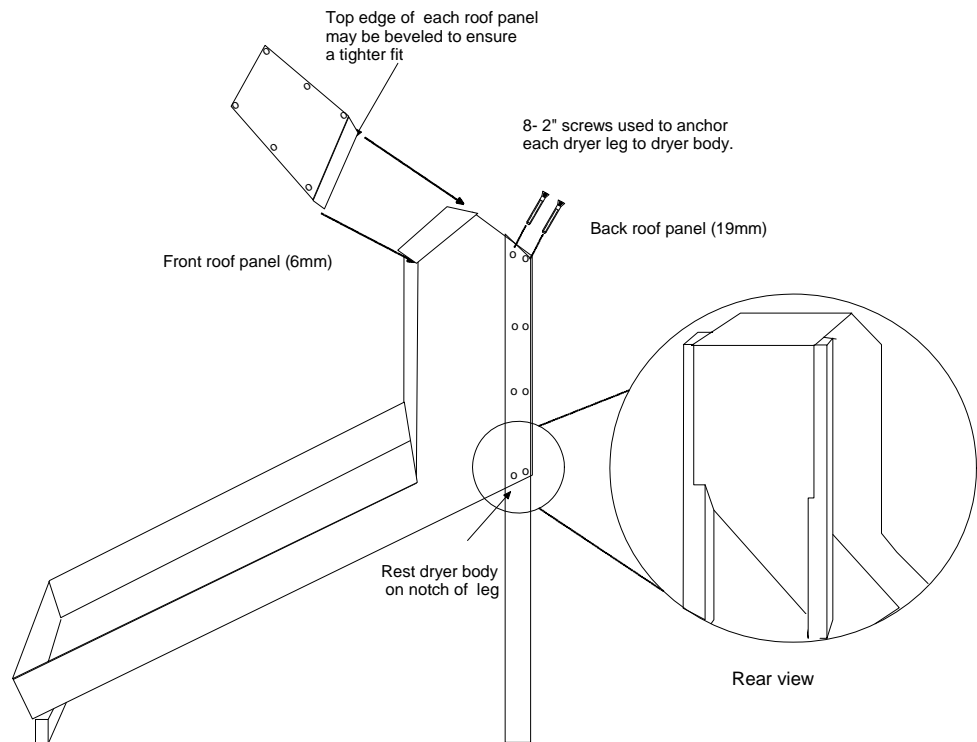

19-Attach back roof panel (19mm) to dryer body using 6-2" screws as shown above. Attach front roof panel (6mm) to dryer body using 6-1 1/4" screws. Roof panels may be beveled to create a tighter fit, but this is not necessary.

Solar Panel Construction—

The solar panel may be constructed using a variety of materials. Individuals should evaluate availability, cost, and durability of materials before building. In the following description heavy duty aluminum foil is used. This is inexpensive and typically available but not very durable. One may also consider using alternate materials like aluminum soda cans or light gauge aluminum sheeting.

20-Paint the bottom of the solar collector area black before proceeding.

21- Drill holes parallel to the bottom panel through the centers of the two struts shown below starting at the center of the strut and drilling one hole every 115.5mm. This should make five holes in each strut.

Side view of side panel showing drilling of struts to support solar panel material.

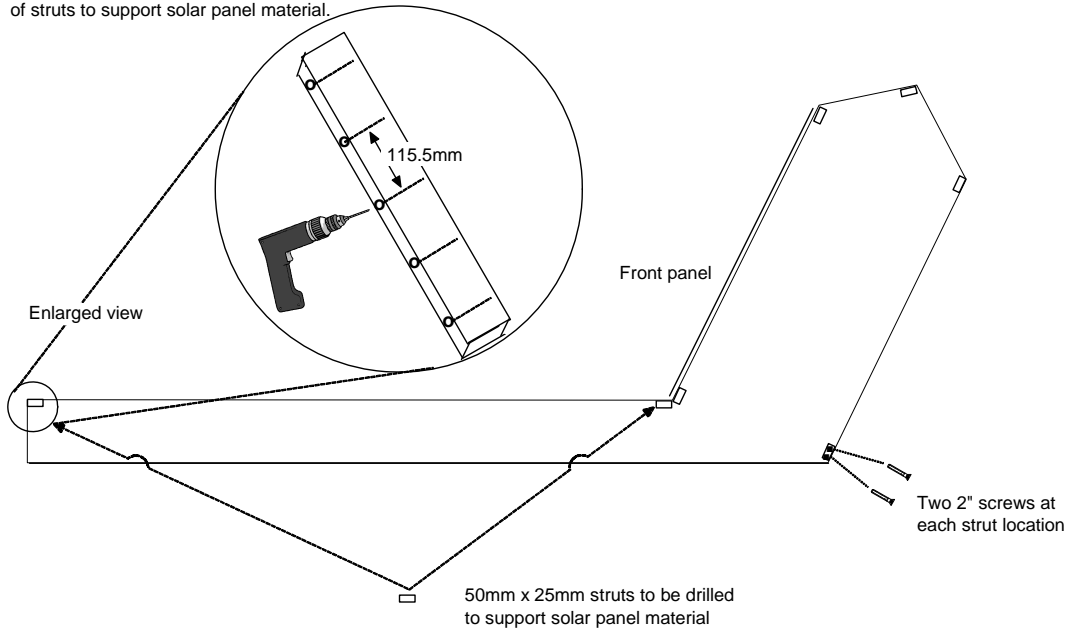

22-String wire through the holes as shown below: this can be done using one length of wire and tightening the wire later on. These wires will support the solar panel material.

View of solar panel showing stringing 20 ga steel wire through struts to support solar panel material.

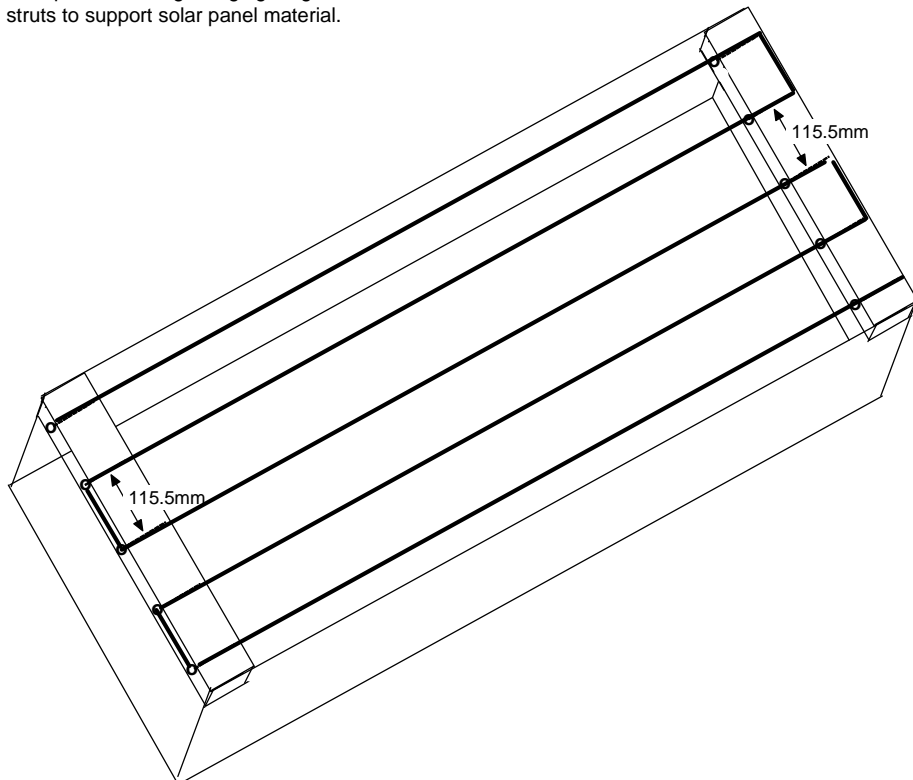

23-The material of choice should be bent to approximately 60° so that it forms deep grooves approximately 115mm deep and bent at the top so as to rest on the wire supports as shown below.

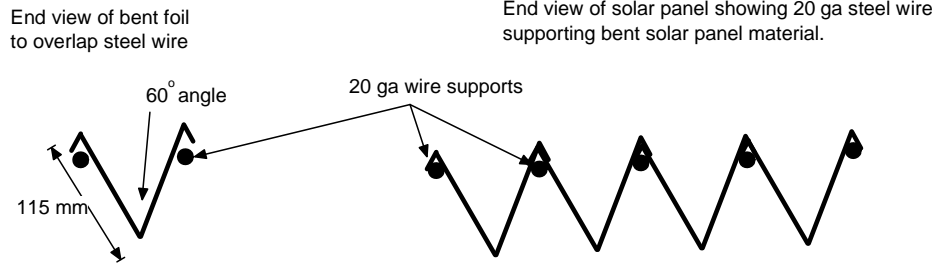

24-Care should be taken when placing the material on the wires to place small quantities of silicon adhesive to the support wires. This will aid in keeping the solar collection material firmly in place.

25-Construct a frame to fit over the top of the solar panel area. Measure the solar panel area to ensure exact measurements for your frame. Use 50mm x 25mm pine laid flat to form the frame. Frame may use 45° cuts at the corners (preferred) or simply butted tight to each frame piece. Cut a groove (dado) to fit the perspex (plexiglass) approximately 12mm deep into the inside edge of each frame piece. **Note:** If you do not have access to a table saw to cut these dados, the plexiglass may be carefully drilled and surface mounted to the backside of the frame with small screws and sealed with silicone sealant.

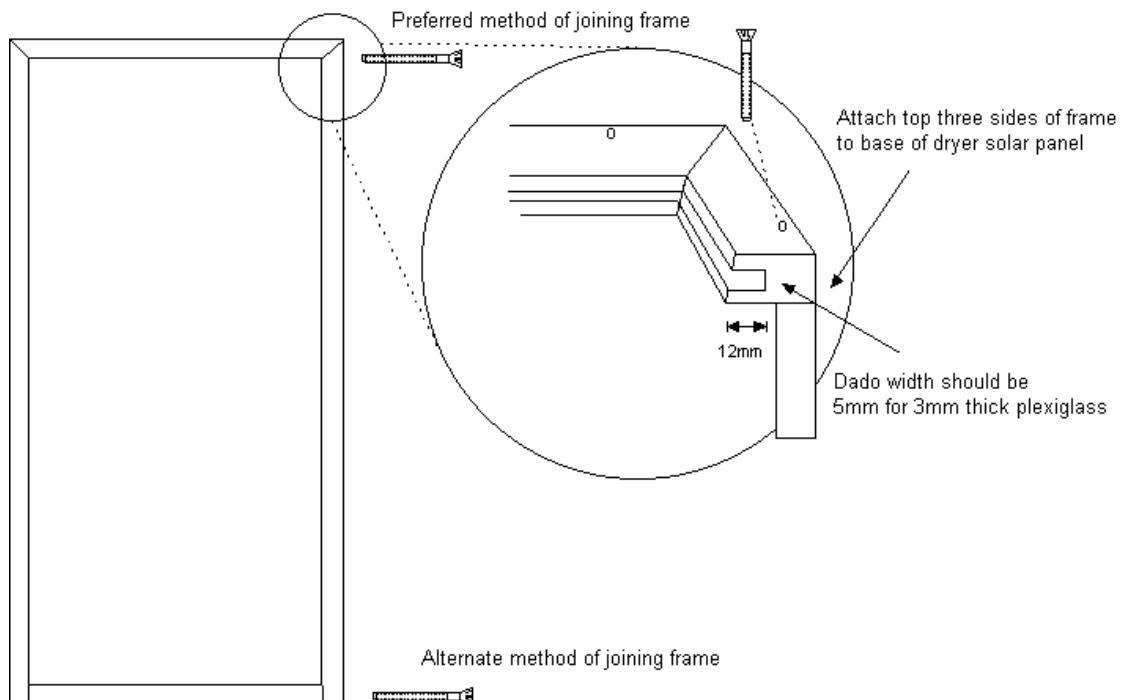

26-Attach top three sides of frame to base of dryer solar panel. Be careful not to place screws through the dado of the frame. Leave the frame bottom off to allow the plexiglass to be slid into the frame.

27-Measure the inside area of the frame and add 20mm to each dimension. Cut the plexiglass to these dimensions and slide it into the frame. Attach the bottom portion of the frame to the bottom strut of the dryer solar panel base.

Food Dryer Cabinet Construction –

28-Cut the 9.5mm dowels into 60 pieces measuring 60mm each in length.

29-Inside the dryer area, mark the centers for 2 vertical lines of fifteen holes 49mm on center, in each side of the dryer as shown below (one line 60mm from the front of the dryer and one line 60mm from the back of the dryer, making a total of four lines of fifteen marks each). Drill at each mark using a 9.5mm drill bit (3/8") to a depth of 18mm. These will be used to insert the small lengths of dowel. The holes should be placed so that their centers are 49mm apart.

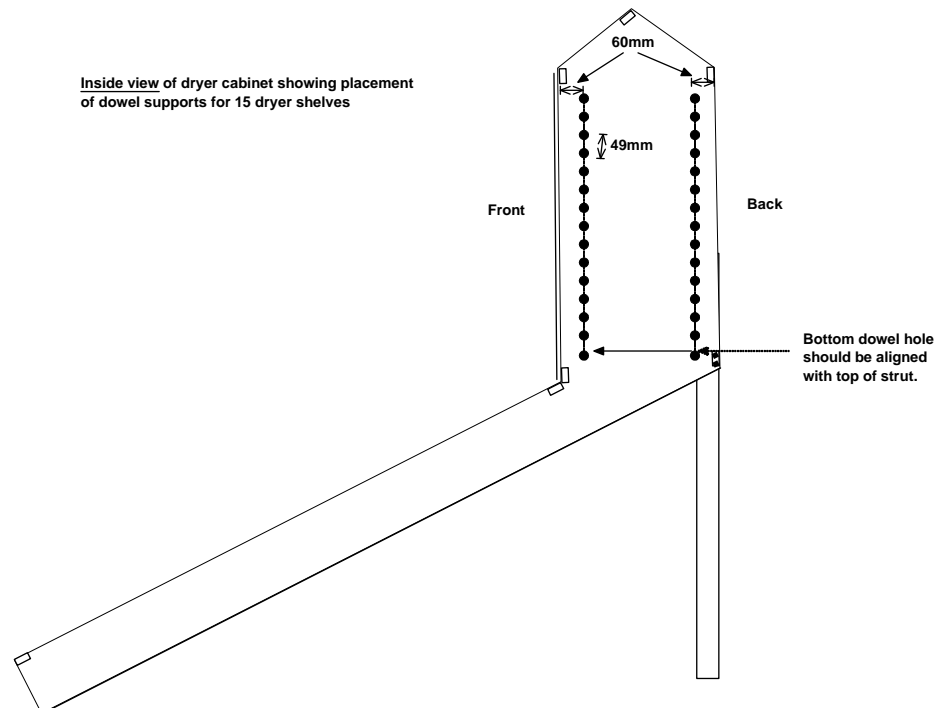

30-Place a small amount of glue on the end of each dowel and then using a hammer, gently pound the dowels into each of the holes to a depth of 18mm. These dowels will support the shelves for the dryer.

31-Measure the final width of the dryer and do a final cut for the door to the back of the dryer. The door should measure near the values of 760mm x 630mm. Attach the door to the back of the solar dryer cabinet using screws provided with the 4" strap hinges or with 1 ¼" wood screws as shown below. Attach 1/8" galvanized chain to hold door at a horizontal position when opened as shown. Attach gate hooks to each side of dryer door to hold door securely and tightly shut.

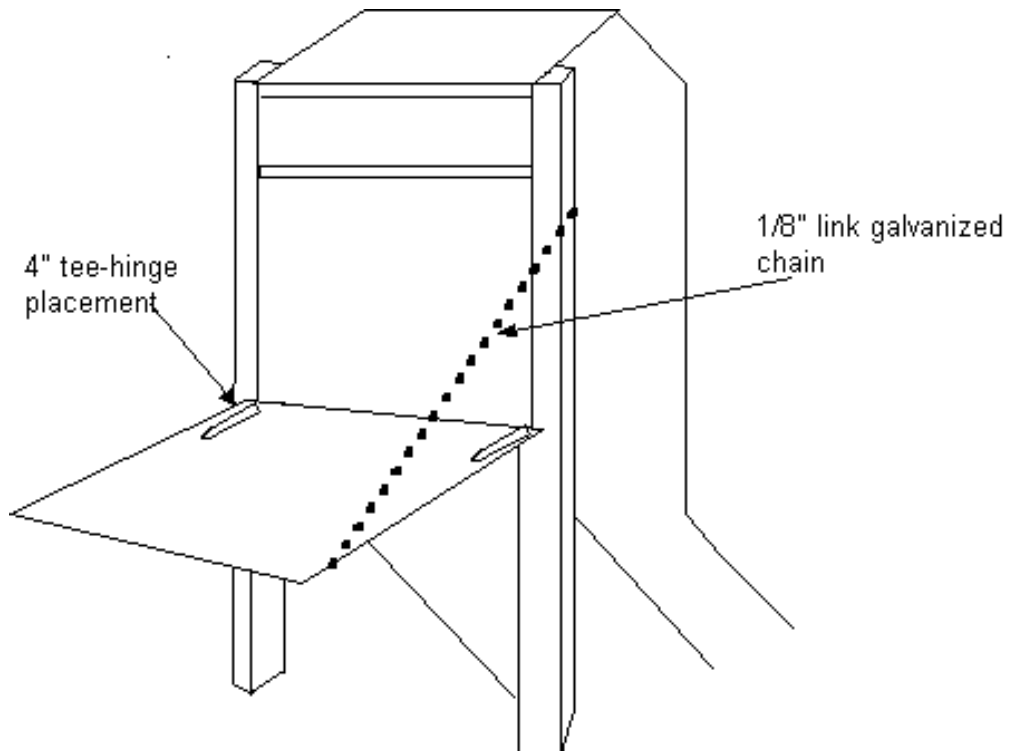

Dryer Shelf Frame Construction –

32-Construct fifteen frames from 50mm x 25mm pine to fit into the shelf support slots in the dryer cabinet. Frames should be approximately 565mm x 400mm. This may be adjusted to fit your specific dryer, but shelf frames should slide freely in and out of dryer cabinet as shown.

33-Construct frames similar to the method described previously in directive number 25. Dado grooves in dryer shelves should only be wide enough to fit the 23 gauge welded mesh. A single cut with the table saw should be adequate width of the dado groove. Cut each groove on the inside edge of each frame piece approximately 15mm deep. If no table saw is available wire mesh can be simply stapled to the frame.

34-Cut fifteen pieces of welded mesh to fit dimensions of frame interior (485mm x 330mm) plus 20mm added to each dimension to fit into the frame groove (505mm x 350mm).

35-Assemble three sides of each dryer shelf frame using glue and 2" wood screws. Slide welded mesh into each frame and attach final side to complete frame. Mesh may be secured in the dado groove with silicone sealant. Ensure frame is square and fits easily into dryer cabinet between shelf supports as shown.

Dryer shelf frame with galvanized wire mesh in shelf support of dryer cabinet.

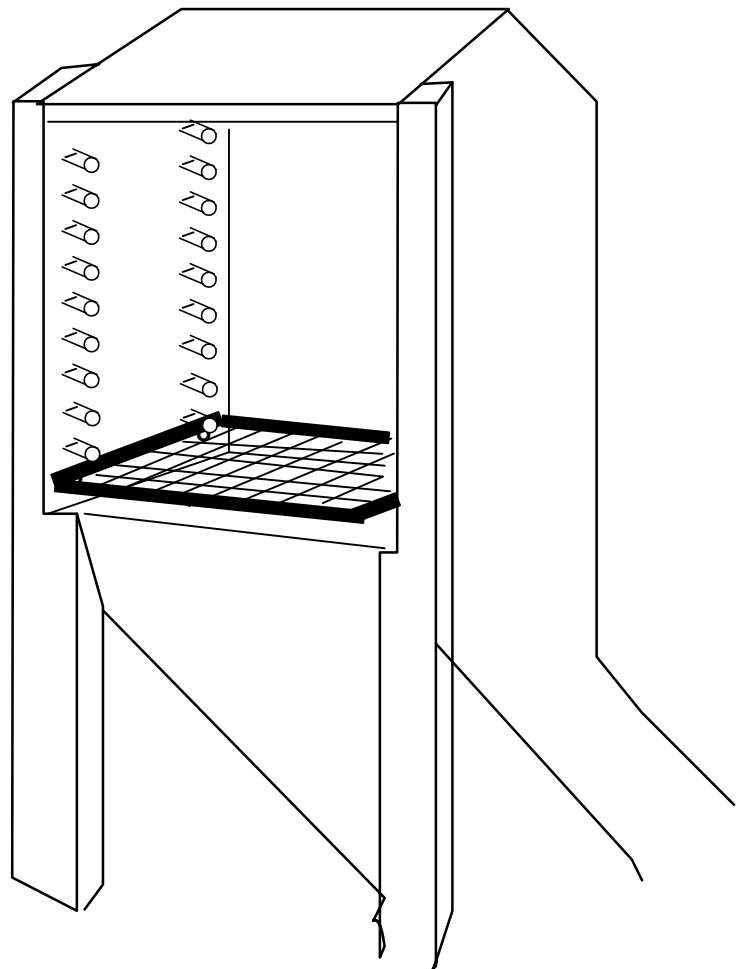

Dryer Chimney Construction –



36- Assemble using glue and nails the remaining chimney pieces (one 19mm thick piece and three 6mm thick pieces) to form a long rectangular chimney approximately 650mm long and 150mm square. Be sure to have one end of the chimney flush leaving the other end with the shorter side panels across from each other as shown in the photos.

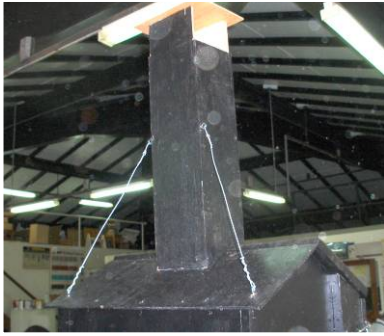

37- Using some extra plywood, construct a small roof for the chimney. This roof should extend a little bit over the sides of the chimney and should leave a gap to allow hot air to escape during use as shown.

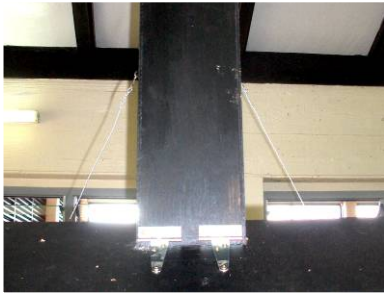

38- Mark on the top of the dryer roof the exact width of the chimney. Note that the chimney has a front (6mm) and back (22mm). Orient the chimney correctly before marking and cutting into the roof of the dryer.

39- Cut a hole in the top of the dryer whose width is the same width as the side to side width of the chimney and whose front to back distance is the same as the front to back **inside** distance of the chimney. Cut the front and back edges of the chimney so that they are flat. This will ensure that the chimney will have a firm base to rest on. The chimney should sit down into the dryer roof along the sides and also be resting on the dryer roof on the front and back edges of the chimney.

40- A set of strap hinges may be attached to the back of the chimney which will allow the chimney to fold down for easier transport. To ensure that the chimney is firm in the upright position, tension lines may be added on the front of the dryer as shown.

41- Paint exterior of dryer with exterior paint to protect from the weather. Black paint will help increase temperature of the drying chamber. Dryer is best stored in a protected area or under a tarp.

42- Bracing may be installed on the leg supports to ensure greater stability.

43- Wheels may also be installed on the dryer to improve mobility of the dryer.

Dryer is now complete!

Solar Drying – Use Manual

1. INTRODUCTION

Use of a solar dryer is an efficient, simple method of producing a shelf-stable food. This manual concentrates on the drying of complex carbohydrate containing foods such as taro, cassava and breadfruit that are predominant in the diets of most Pacific Islanders. Even though these foods are specifically discussed, other root crop foods and fruits may be dried using the principles discussed in this manual. For foods with a rapid rate of deterioration, such as cassava, taro, and breadfruit, this method is especially useful. Through solar drying, these foods can be stored for long periods and used in emergency situations. Food preparation, drying, storage, and rehydration are all key components of producing a quality, shelf stable product. If dried and stored properly, these foods should last at least one year.

2. FOOD PREPARATION

With all products, it is important that the beginning product is fresh: use of a poor beginning product leads to a poor finished product. If possible, begin sample preparation within one or two days of harvest of the product.

a. Peeling: Begin food preparation by peeling the product being dried. Products may be peeled in the traditional or customary way. Rinsing with water may be necessary during and/or after the peeling process to remove excess dirt.

b. Slicing: Once the food has been peeled, slicing can begin. For best results, the products may need to be sliced different than traditional methods. The process of drying and rehydration requires specific slicing methods.

Taro slices should be between $\frac{1}{4}$ " and $\frac{3}{8}$ " (7-10 mm) thick. For larger pieces, it is necessary to cut the sliced pieces in halves. Smaller pieces will decrease total drying time.



Taro – before (right) and after (left) peeling

To slice cassava, first cut the cassava into 3"-4" (5-8 cm) sections. These shorter sections will help the cassava dry quicker. From these sections, cut the cassava so that it is no more than ½" (13 mm) at its thickest part.



Peeled and unpeeled cassava sections

Breadfruit slices should be cut approximately $\frac{3}{8}$ " (1 cm) thick. After slicing, the center (seeded) section will need to be cut out of some pieces.

3. FOOD DRYING

- a. **Placement on the Drying Rack:** After the food has been sliced, it is now ready to be put on the drying rack. Place a single layer of slices on the drying rack, with as little contact between pieces as possible. With more surface area exposed to air, the pieces will dry better.
- b. **Rotating Racks within the Solar Dryer:** When the pieces have been placed on the drying rack, they are now ready for drying in the solar dryer. Open the back of the dryer, and place one rack in each of the slots built into the dryer. Throughout the drying process, the racks may be rotated to help the products dry evenly.

- c. **Rotating the Dryer:** Throughout the drying process, it is important to rotate the entire dryer. To create the most effective drying environment, the plexiglass (pespex) face of the dryer should be in direct sunlight. This is accomplished by periodically rotating the dryer until the side of the dryer and the shadow form a continuous line.



Shadow cast by direct sunlight

- d. **Weather Adjustments:** During the drying process, adjustments may be needed periodically to adapt to the current weather. For example, if it begins to rain, it is best to pull the dryer into a covered area during the rain.

4. FOOD REMOVAL

In order to obtain the best finished product, the dried food must be removed from the dryer at the proper time. Because this time varies between the foods being dried, general rules must be applied. In the case of root crops, if the food is dried to a proper level, it will snap sharply when broken. It will also be distinctly dry and brittle. In addition, if the pieces begin to crack, they should be dry enough to be removed from the dryer. When drying fruits with higher sugar content, a properly dried product will still be soft and leathery with no visible moisture. Pieces should not stick to each other, but spring apart after being pressed together.

5. FOOD PACKAGING

Once the food has been dried, it is ready to be packaged and stored. Following several guidelines will increase the quality and shelf-life of the product:

- a. **Package:** For optimal results, Mylar™ pouches (a foil-plastic laminate) are recommended. These pouches will also require a heat sealer to create an airtight environment in the bag. If these packages are not available at stores, they may be obtained through the Church of Jesus Christ of Latter-Day Saints Distribution Services. Alternative methods are available, but these methods will decrease significantly the shelf-life of the product. Such methods include using polyethylene plastic (requiring a heat sealer), or Ziploc™ type sacks. Glass jars with a tight seal may also be used. If using an alternative method, creating an airtight environment is crucial.
- b. **Oxygen Absorbers:** Before sealing the storage package, addition of oxygen absorbing packets is strongly recommended. This packet will absorb whatever oxygen may be present, thus reducing the chance of microbial growth. Oxygen absorbers may also be ordered through the Church of Jesus Christ of Latter-Day Saints Distribution Services. These absorbers work best when combined with the Mylar™ pouches, but may also be used with alternative packaging methods.
- c. **Environment:** The storage environment is important in preserving foods, especially those not packaged in Mylar™. A dark, cool, and dry environment is most suitable for the preservation of dried foods. In contrast, a wet, warm, and/or sunlit area will *decrease the shelf-life* of the dried products. In addition, rodents and pests are capable of chewing through most types of packages. To remedy this, an environment free or resistant to rodents and pests is recommended.

6. REHYDRATION

In the case of dried root crops, before eating the dried food, it must be rehydrated (have water added back into the product) and cooked. For best results, soak the dried product overnight in water. Once this has been done, boil the food until it has the desired texture. After rehydration, the food may be prepared in a usual manner.

Fruits may be eaten directly in the dehydrated form.

References

- Scanlin, D. 1997, Indirect, through-pass, solar food dryer. Home Power. February-March 62-72.
- Midilli. A., Kucuk, H., and Yapar, Z., 2002. A new model for single-layer drying. Drying Technology, 20(7) 1503-1513.
- Vlachos, N.A., Karapantsios, T.D., Balouktsis, A.I., Chassapis, D. 2002. Design and testing of a new solar tray dryer. Drying Technology. 20(6) 1243-1271.
- Sharma, V.K., Calangelo, A., and Spagna. 1995. Experimental investigation of different solar dryers suitable for fruit and vegetable drying. Renewable Energy. 6(4) 413-424.