



Theses and Dissertations

2004-04-16

Analysis of Clinically Important Compounds Using Electrophoretic Separation Techniques Coupled to Time-of-Flight Mass Spectrometry

Zlatuse Durda Peterson
Brigham Young University - Provo

Follow this and additional works at: <https://scholarsarchive.byu.edu/etd>

 Part of the [Biochemistry Commons](#), and the [Chemistry Commons](#)

BYU ScholarsArchive Citation

Peterson, Zlatuse Durda, "Analysis of Clinically Important Compounds Using Electrophoretic Separation Techniques Coupled to Time-of-Flight Mass Spectrometry" (2004). *Theses and Dissertations*. 23.
<https://scholarsarchive.byu.edu/etd/23>

This Dissertation is brought to you for free and open access by BYU ScholarsArchive. It has been accepted for inclusion in Theses and Dissertations by an authorized administrator of BYU ScholarsArchive. For more information, please contact scholarsarchive@byu.edu, ellen_amatangelo@byu.edu.

ANALYSIS OF CLINICALLY IMPORTANT COMPOUNDS USING
ELECTROPHORETIC SEPARATION TECHNIQUES COUPLED
TO TIME-OF-FLIGHT MASS SPECTROMETRY

by

Zlatuše D. Peterson

A dissertation submitted to the faculty of
Brigham Young University
in partial fulfillment of the requirement for the degree of

Doctor of Philosophy

Department of Chemistry and Biochemistry

Brigham Young University

April 2004

BRIGHAM YOUNG UNIVERSITY

GRADUATE COMMITTEE APPROVAL

of a dissertation submitted by

Zlatuše D. Peterson

This dissertation has been read by each member of the following graduate committee and by majority vote has been found to be satisfactory.

Date

Steven W. Graves, Chair

Date

Milton L. Lee

Date

Steven R. Goates

Date

David V. Dearden

Date

Craig D. Thulin

BRIGHAM YOUNG UNIVERSITY

As a chair of the candidate's graduate committee, I have read the dissertation of Zlatuše D. Peterson in its final form and have found that (1) its format, citations, and bibliographical style are consistent and acceptable and fulfill university and department style requirement; (2) its illustrative materials including figures, tables, and charts are in place; and (3) the final manuscript is satisfactory to the graduate committee and is ready for submission to the university library.

Date

Steven W. Graves
Chair, Graduate Committee

Accepted for the Department

Noel L. Owen
Graduate Coordinator

Accepted for the College

G. Rex Bryce, Associate Dean
College of Physical and Mathematical Sciences

ABSTRACT

ANALYSIS OF CLINICALLY IMPORTANT COMPOUNDS USING ELECTROPHORETIC SEPARATION TECHNIQUES COUPLED TO TIME-OF-FLIGHT MASS SPECTROMETRY

Zlatuše D. Peterson

Department of Chemistry and Biochemistry

Doctor of Philosophy

Capillary electrophoretic (CE) separations were successfully coupled to time-of-flight mass spectrometric (TOFMS) detection for the analysis of three families of biological compounds that act as mediators and/or indicators of disease, namely, catecholamines (dopamine, epinephrine, norepinephrine) and their O-methoxylated metabolites (3-methoxytyramine, norepinephrine, and normetanephrine), indolamines (serotonin, tryptophan, and 5-hydroxytryptophan), and angiotensin peptides. While electrophoretic separation techniques provided high separation efficiency, mass spectrometric detection afforded specificity unsurpassed by other types of detectors.

Both catecholamines and indolamines are present in body fluids at concentrations that make it possible for them to be determined by capillary zone electrophoresis coupled to TOFMS without employing any preconcentration scheme beyond sample work up by

solid phase extraction (SPE). Using this hyphenated approach, submicromolar levels of catecholamines and metanephrines in normal human urine and indolamines in human plasma were detected after the removal of the analytes from their biological matrices and after preconcentration by SPE on mixed mode cation-exchange sorbents. The CE-TOFMS and SPE methods were individualized for each group of compounds. While catecholamines and metanephrines in urine samples were quantitated using 3,4-dihydroxybenzylamine as an internal standard, deuterated isotopes, considered ideal internal standards, were used for the quantitation of indolamines.

Because the angiotensin peptides are present in biological fluids at much lower concentrations than the previous two families of analytes, their analysis required the application of additional preconcentration techniques. In this work, the coupling of either of two types of electrophoretic preconcentration methods - field amplified injection (FAI) and isotachopheresis (ITP) - to capillary zone electrophoresis with both UV and MS detection was evaluated. Using FAI-CE-UV, angiotensins were detected at ~1 nM concentrations. Using similar conditions but TOFMS detection, the detection limits were below 10 nM. ITP was evaluated in both single-column and two-column comprehensive arrangements. The detection limits achieved for the ITP-based techniques were approximately one order of magnitude higher than for the FAI-based preconcentration. While the potential usefulness of these techniques was demonstrated using angiotensins standards, substantial additional research would be required to allow these approaches to be applied to plasma as part of clinical assays.

ACKNOWLEDGEMENTS

First and foremost I would like to thank my advisor, Dr. Steven W. Graves, for patiently teaching me, coaching me, encouraging, inspiring and supporting me academically, professionally, and personally during my graduate studies. I admire, honor, and respect him not only as a scientist but even more importantly as the kind and caring person that he is.

I also wish to thank my advisory committee members, Dr. Milton L. Lee, Dr. Steven R. Goates, Dr. David V. Dearden and Dr. Craig D. Thulin, for their support, informative and constructive feedback and thorough review of my dissertation. I would like to thank Dr. Milton L. Lee for his role as a collaborator in all my work and for the opportunity to work in his laboratory. I am especially thankful to Dr. Steven R. Goates for the friendship he has extended to me over the last five years.

I extend my gratitude to David C. Collins for training me on the Jaguar mass spectrometer, Edgar D. Lee, Wayne H. Lee, Randy W. Waite and Frank Cordova for their assistance with the operation and maintenance of the mass spectrometer, Susan L. Tachka for her assistance and friendship, Bart Whitehead, Keith Kling and Jim Armstrong from the BYU Instrument Shop for technical support, and to many of the wonderful people at Brigham Young University who have touched my life both professionally and personally.

My deepest love and gratitude belong to my beloved husband, Duncan Peterson, for inspiring and supporting me and for standing by me “come rain or shine” in this adventure called life. I also express my love and gratitude to my parents, Jan and Marie Durdovi, for all they have given me and sacrificed for me, and to my parents-in-law, Paul

and Nancy Peterson, for accepting me into their family as their own daughter. I am grateful for all the wonderful friends who bring light and meaning to my life, especially Doug Moore, my surrogate father, who has greatly assisted me in becoming who I am today.

And finally and most importantly, I thank God, the Creator of the Universe, for my life, for all I am, and for all the wonderful learning opportunities I have had and will yet have on this journey. He has sent me angels, both seen and unseen, to guide me and protect me. His love is the greatest power in the Universe.

TABLE OF CONTENTS

LIST OF FIGURES	xi
LIST OF TABLES	xiii
LIST OF ACRONYMS AND ABBREVIATIONS	xiv
CHEMICAL STRUCTURES OF STANDARD COMPOUNDS	xvi
CHAPTER I. INTRODUCTION	1
I.1. BACKGROUND INFORMATION	1
I.2. REFERENCES	5
CHAPTER II. INSTRUMENTATION AND EXPERIMENTAL PROCEDURES	9
II.1. CAPILLARY ELECTROPHORESIS WITH UV DETECTION	9
II.2. COLUMN COATING.....	9
II.3. TIME-OF-FLIGHT MASS SPECTROMETER	10
II.4. ELECTROSPRAY INTERFACE.....	12
II.5. COMPREHENSIVE ISOTACHOPHORESIS-CAPILLARY ELECTROPHORESIS.....	14
II.6. SOLID PHASE EXTRACTION.....	15
II.7. REFERENCES.....	17
CHAPTER III. DETERMINATION OF CATECHOLAMINES AND METANEPHRINES IN URINE BY CAPILLARY ELECTROPHORESIS/ ELECTROSPRAY IONIZATION/TIME-OF-FLIGHT MASS SPECTROMETRY	19
III.1. INTRODUCTION	19
III.2. EXPERIMENTAL.....	21
III.2.1. Materials and chemicals.....	21
III.2.2. Buffers and standard solutions.....	21
III.2.3. Instrumentation	22
III.2.4. Solid phase extraction.....	22

III.2.5. Recovery studies	23
III.2.6. Linearity, detection limits, and quantitation	24
III.3. RESULTS AND DISCUSSION	25
III.3.1. CE separation of catecholamines and metanephrines	25
III.3.2. CE-TOFMS analysis of standard compounds.....	27
III.3.3. Sample cleanup	30
III.3.4. SPE-CE-TOFMS of catecholamines and metanephrines in urine	34
III.4. CONCLUSIONS.....	36
III.5. REFERENCES	37
CHAPTER IV. DETERMINATION OF SEROTONIN AND ITS PRECURSORS IN HUMAN PLASMA BY CAPILLARY ELECTROPHORESIS/ ELECTROSPRAY IONIZATION/TIME-OF-FLIGHT MASS SPECTROMETRY	41
IV.1. INTRODUCTION	41
IV.2. EXPERIMENTAL.....	43
IV.2.1. Materials and chemicals	43
IV.2.2. Buffers and standard solutions.....	44
IV.2.3. Instrumentation	45
IV.2.4. Sample collection, preparation, and solid phase extraction.....	45
IV.2.5. Recovery studies	47
IV.2.6. Linearity, detection limits, and quantitation for CE-TOFMS.....	47
IV.3. RESULTS AND DISCUSSION.....	48
IV.3.1. CE separation of indolamines	48
IV.3.2. CE-TOFMS analysis of standard compounds	51
IV.3.3. Sample cleanup.....	56
IV.3.4. Determination of serotonin and its precursors in SPE extracts of human platelet-rich plasma.....	60
IV.4. CONCLUSIONS	67
IV.5. REFERENCES	68

CHAPTER V. ELECTROPHORETIC SENSITIVITY ENHANCEMENT TECHNIQUES FOR THE ANALYSIS OF ANGIOTENSINS BY CAPILLARY ELECTROPHORESIS COUPLED TO TIME-OF-FLIGHT MASS SPECTROMETRY	73
V.1. INTRODUCTION	73
V.2. EXPERIMENTAL	80
V.2.1. Materials and chemicals.....	80
V.2.2. Instrumentation	81
V.3. RESULTS AND DISCUSSION	82
V.3.1. Separation of angiotensins using CE-UV	82
V.3.2. Separation of angiotensins using CE-TOFMS.....	86
V.3.3. Separation of angiotensins using ITP-UV	91
V.3.4. Separation of angiotensins using ITP-TOFMS.....	91
V.3.5. Preconcentration methods for CE analysis of angiotensins with UV detection	95
V.3.5.1. Field amplified injection	96
V.3.5.2. Transient ITP-CE-UV without sample matrix removal.....	98
V.3.5.3. Counterflow ITP-CE-UV	102
V.3.6. Single-capillary preconcentration techniques coupled to TOFMS	105
V.3.7. Comprehensive ITP-CE-TOFMS	115
V.3.7.1. Analysis of a high concentration sample	116
V.3.7.2. Analysis of a low concentration sample	118
V.4. CONCLUSIONS.....	122
V.5. REFERENCES.....	124
 CHAPTER VI. RECOMMENDATIONS FOR FUTURE RESEARCH.....	 129
VI.1. RECOMMENDATIONS FOR FUTURE RESEARCH	129
VI.2. REFERENCES	132

LIST OF FIGURES

Figure II.1. Liquid sheath electrospray interface.....	14
Figure III.1. CE-UV separation of 1 μ M catecholamine standards on uncoated and PVA-coated capillaries	26
Figure III.2. CE-TOFMS analysis of 1 μ M catecholamine standards.....	28
Figure III.3. CE-UV analysis of an SPE extract of normal human urine before and after spiking with catecholamine and metanephrine standards.....	33
Figure III.4. CE-TOFMS analysis of an SPE extract of normal human urine.....	34
Figure IV.1. CE-UV separation of indolamine standards.....	50
Figure IV.2. CE-TOFMS analysis of indolmine standards	55
Figure IV.3. CE-UV analysis of an SPE extract of healthy human plasma	61
Figure IV.4. CE-UV analysis of an SPE extract of pathological plasma	62
Figure IV.5. CE-TOFMS analysis of an SPE extract of healthy human plasma.....	63
Figure IV.6. CE-TOFMS analysis of an SPE extract of pathological plasma.....	64
Figure V.1. CE-UV separation of a 10 μ M angiotensin mixture in different background electrolytes	85
Figure V.2. CE-TOFMS analysis of a 10 μ M angiotensin mixture in different background electrolytes	89
Figure V.3. ITP-UV separation of a 30 μ M mixture of angiotensins.....	92
Figure V.4. ITP-TOFMS of mixtures of angiotensins of decreasing concentrations	92
Figure V.5. Comparison of CE-UV, FAI-CE-UV and ITP-CE-UV analysis of angiotensin mixtures	101

Figure V.6. ITP-CE-MS analysis of a 1 μ M angiotensin mixture.....	107
Figure V.7. FAI-CE-MS analysis of a 0.1 μ M angiotensin mixture	108
Figure V.8. ITP-CE-MS analysis of a 1 μ M angiotensin mixture.....	110
Figure V.9. FAI-CE-MS analysis of a 0.1 μ M angiotensin mixture	111
Figure V.10. CE-MS analysis of a 1 μ M angiotensin mixture	112
Figure V.11. FAI-CE-MS analysis of a 10 nM angiotensin mixture.....	113
Figure V.12. ITP-CE-MS analysis of a 0.1 μ M angiotensin mixture.....	114
Figure V.13. Comprehensive ITP-CE-TOFMS of a high-concentration (30 μ M) angiotensin mixture.....	120
Figure V.14. Comprehensive ITP-CE-TOFMS of a low-concentration angiotensin mixture.....	121

LIST OF TABLES

Table III.1. Regression equations, correlation coefficients, and LOD's for CE-UV of catecholamine and metanephrine standards	27
Table III.2. Mass-to-charge ratios, relative abundances, and CE-MS LOD's of protonated analyte molecular ions	30
Table III.3. SPE recoveries of catecholamines and metanephrines from spiked urine samples	32
Table III.4. Catecholamine and metanephrine levels in a spot collection of human urine	36
Table IV.1. Mass-to-charge ratios and relative abundances of protonated molecular ions and fragment ions of angiotensin peptides	54
Table IV.2. Regression equations, correlation coefficients and LOD's for CE-TOFMS of indolamine standards	54
Table IV.3. SPE recoveries of indolamines from plasma samples	60
Table V.1. Regression equations, correlation coefficients and LOD's for CE-UV of angiotensin standards	84
Table V.2. Charge states, m/z ratios and relative abundances of angiotensin ions	88
Table V.3. Regression equations, correlation coefficients and LOD's for FAI-CE-UV of angiotensin standards	98
Table V.4. Regression equations, correlation coefficients and LOD's for transient ITP-CE-UV of angiotensin standards	102

LIST OF ACRONYMS AND ABBREVIATIONS

BGE	background electrolyte
C	Coulomb
°C	centigrade
CE	capillary electrophoresis
cm	centimeter
E	electric field strength
EDTA	ethylenediaminetetraacetic acid
EOF	electroosmotic flow
ESI	electrospray ionization
GC	gas chromatography
h	hour
HAc	acetic acid
HPLC	high performance liquid chromatography
i.d.	internal diameter
IEF	isoelectric focusing
ITP	isotachopheresis
L	liter
LE	leading electrolyte
LIF	laser induced fluorescence
LOD	limit of detection
M	molarity (mol/L)

m	meter
m	milli (10^{-3})
min	minute
mL	milliliter
MS	mass spectrometry
n	nano (10^{-9})
o.d.	outer diameter
PVA	polyvinylalcohol
RIA	radioimmunoassay
RA	relative abundance
s	second
TE	terminating or trailing electrolyte
TEA	triethylamine
TOFMS	time-of-flight mass spectrometry
UV	ultraviolet
Vis	visible
μ	micro (10^{-6})
μ	electrophoretic mobility
μ L	microliter (10^{-6} liter)
μ m	micrometer (10^{-6} meter)

CHEMICAL STRUCTURES OF STANDARD COMPOUNDS

CATECHOLAMINES

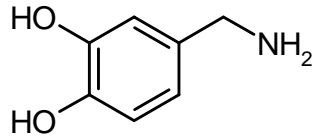

3,4-hydroxybenzylamine

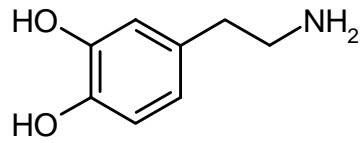

dopamine

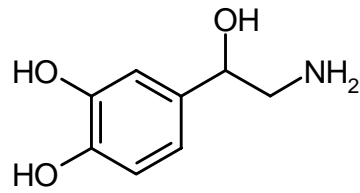

norepinephrine

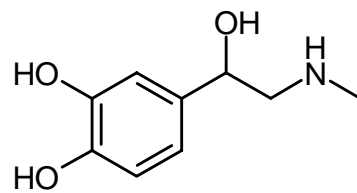

epinephrine

METANEPHRINES

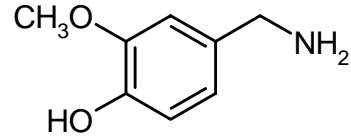

4-hydroxy-3-methoxybenzylamine

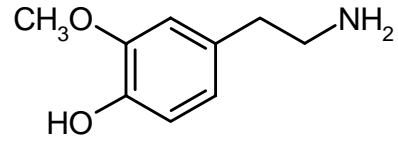

3-methoxytyramine

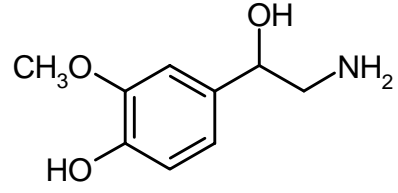

normetanephrine

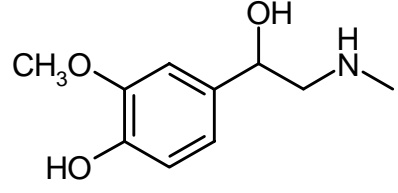

metanephrine

SEROTONIN AND ITS PRECURSORS

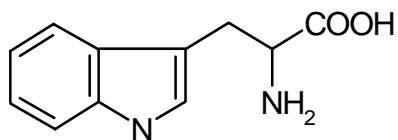

tryptophan

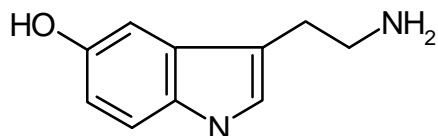

5-hydroxytryptamine
(serotonin)

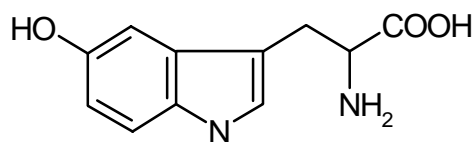

5-hydroxytryptophan

ANGIOTENSIN PEPTIDES

Peptide	Size	Net charge	Sequence
			- + + +
AI	10	+2	Asp-Arg-Val-Tyr-Ile-His-Pro-Phe-His-Leu
AII	8	+1	Asp-Arg-Val-Tyr-Ile-His-Pro-Phe
AIII	7	+2	Arg-Val-Tyr-Ile-His-Pro-Phe
AI(1-7)	7	+1	Asp-Arg-Val-Tyr-Ile-His-Pro
AIV	6	+1	Val-Tyr-Ile-His-Pro-Phe

CHAPTER I

INTRODUCTION

I.1. BACKGROUND INFORMATION

One of the most frequent causes of death, especially in developed countries, is hypertension, a disease characterized by increased blood pressure [1]. The maintenance of normal blood pressure involves the complex integration of several known and potentially unknown systems and factors. Furthermore, when blood pressure increases, the resultant damage to the cardiovascular system and target organs, such as the brain, heart, and kidney, is better understood and described than the fundamental cause of the hypertensive process. Many hormones have been found to affect the blood pressure. These include the steroid hormones (mineralocorticoids, glucocorticoids, and estrogens), thyroid hormones, catecholamines, serotonin, and the polypeptide hormones (angiotensins, vasopressin, and others). Excess production of these hormones has been linked to various hypertensive conditions [1].

There are numerous types and causes of hypertension. To properly diagnose a particular type of this disease and design an effective treatment plan, it is often crucial to evaluate the levels of potential disease mediators or markers. These markers are biologically important molecules that signal by their presence, absence, elevated or decreased levels, an abnormality, which may assist in explaining or tracking a disease. Clinical laboratories depend on sensitive, specific and efficient methods for the assessment of many such biomolecules. However, the design of assays for many

compounds is still quite problematic [2]. Such compounds are often present in very small quantities in body fluids and/or are susceptible to rapid degradation. Also, the matrix of a biological specimen is quite complex and, thus, extensive sample preparation steps often become a necessary prelude to the assay. Most importantly, many existing assays are not completely specific [2,3].

In the last several years, the coupling of various separation techniques to mass spectrometry has become a focus of substantial research. Although some analytical methods such as radioimmunoassays [2-4] show great sensitivity, they cannot match the identification power and selectivity of a separation technique coupled to mass spectrometric detection [5]. The mass spectrometer can identify the analytes based on their mass-to-charge ratios and thus provide the detection specificity that most other types of detectors lack.

Among separation techniques, gas chromatography (GC) and high performance liquid chromatography (HPLC) are now routinely coupled to mass spectrometric detection for use in the pharmaceutical industry and in clinical laboratories [6]. In recent years, however, capillary electrophoresis (CE) has been growing in popularity as a separation technique complementary to HPLC [7-9].

Separation in CE is based on the differences in electrophoretic mobilities of charged analytes migrating in an electrolyte solution under the influence of a strong electric field. The electrophoretic mobility μ ($\text{cm}^2 \text{V}^{-1} \text{s}^{-1}$) is defined by the following equation:

$$\mu = v/E = q/6\pi\eta r \quad (\text{I.1})$$

where v is the electrophoretic velocity (cm s^{-1}), E is the electric field strength (V cm^{-1}), q is the net charge on the analyte (C), r is the ionic radius (cm), and η is the viscosity of the electrolyte ($\text{g cm}^{-1} \text{s}^{-1}$).

CE has several advantages over chromatographic methods. Typically, CE separations are performed in capillaries with internal diameters of 20-100 μm which facilitates efficient dissipation of Joule heat created by the passage of electric current. In this way, high electric field strengths (hundreds of V cm^{-1}) can be used for CE separations, resulting in short analysis times and high peak efficiencies (up to millions of theoretical plates). The costs of CE analyses are lower than costs of chromatographic methods due to low to negligible consumption of organic solvent and smaller sample volumes (at most a few μL). The CE capillaries are also relatively inexpensive compared to HPLC or GC columns [10,11].

While the mass sensitivity of CE is far superior to that of HPLC [12], the low sample loading capacities (10-100 nL) and the short detection path length of the small internal diameter capillaries result in a relatively high concentration limit of detection (cLOD) [10,11,13-15]. This cLOD limitation is particularly apparent when conventional detectors such as ultraviolet/visible absorption (UV/Vis) or electrical conductivity are used for trace analysis. This is especially a problem for many biological specimens, where analytes are often present at concentrations below the detector cLOD [11].

There are two general approaches to increasing the sensitivity of CE methods: a) improvements in detection, and b) increasing the sample amount loaded onto the capillary [10,11]. In order to extend the optical path length, fused silica capillaries with a

bubble cell [16,17], Z-shaped cell [18,19] or multireflection cell [20] and rectangularly shaped capillaries [21] have been used. The sensitivity gains were about two to three for the bubble cell, and 20-40 with the other modifications. However, the disadvantages of using a Z-cell or multireflection cell are loss of separation efficiency due to the large cell volume and the increased cost and technical difficulty in implementing these devices. The sensitivity gain obtained by Tsuda et al. using rectangular capillaries was about 20; however, these capillaries are also prone to breakage due to their thin walls. Moreover, the borosilicate glass prevents the use of wavelengths below about 300 nm and, thus, reduces the sensitivity and flexibility of the system.

Substantial sensitivity improvements have been achieved with laser-induced fluorescence (LIF) detection [11]. However, few compounds exhibit native fluorescence, and therefore derivatization procedures must be implemented prior to detection. There are several disadvantages to such derivatization. Individual compounds may form more than one reaction product with the fluorescent tag, and it may be more difficult to quantitatively tag a compound present at very low concentration in the sample. Finally, the added mass of the tag may decrease the separation selectivity if the derivatization is performed prior to separation [11].

An alternative way of increasing sensitivity is to increase the amount of sample loaded onto the capillary. This can be done off-line, using for example liquid-liquid or solid phase extraction techniques to preconcentrate the analytes prior to injection into the capillary, or in an on-line arrangement. Several approaches to on-line sample preconcentration have been explored. Thompson et al. [22] divides these approaches into two categories: (1) sorption, including membrane preconcentration [11,23,24] and solid

phase extraction [11,25,26], and (2) electrophoretic methods, such as sample stacking [11,27-30], field amplified injection [10,11,31], isotachopheresis [7,13,29,32,33] and capillary isoelectric focusing [34-37] (for protein and peptide analysis). Of these, the electrophoretic methods are usually simpler and more straightforward, because they most often do not require any modifications of the separation capillary or the use of elution solvents which may complicate the subsequent separation of the analytes.

In summary then, many small, low concentration molecular species are clinically important but problematic to assay. Consequently, the objective of my research as reported in this dissertation was to evaluate the potential of electrophoretic separation techniques coupled to mass spectrometric detection for the determination of three families of compounds that have been linked to hypertension, namely, catecholamines, indolamines, and angiotensins, each of these presenting its own set of challenges and each requiring a customized approach.

I.2. REFERENCES

- [1] E.G. Biglieri, J.D. Baxter, in P. Felig, J.D. Baxter, A.E. Broadus, L.A. Frohman (Eds.), *Endocrinology and Metabolism*, McGraw Hill, Inc., New York, 1981, Ch.14.
- [2] Q.C. Meng, J. Durand, Y.-F. Chen, S. Oparil, *J. Chromatogr.* 614 (1993) 19.
- [3] B.J. Ledwith, M.K. Cahill, L.S. Losse, S. M. Satiritz, R.S. Eydeloth, A.L. Dallob, W.K. Tanaka, S.M. Galloway, W.W. Nichols, *Anal. Biochem.* 213 (1993) 349.
- [4] M. Hanssens, M.J.N.C. Keirse, P.J. Lijnen, M.-J. Kucharski, C. Luyten, F.A. Van Assche, *J. Biochem. Biophys. Methods*, 21 (1990) 103.

- [5] F. Artigas, E. Gelpí, J. Chromatogr. 394 (1987) 123.
- [6] M.M. Kushnir, F.M. Urry, E.L. Frank, W.L. Roberts, B. Shushan, Clin. Chem. 48 (2002) 323.
- [7] N.J. Reinhoud, U.R. Tjaden, J. van der Greef, J. Chromatogr. 641 (1993) 155.
- [8] J.D. Henion, A.V. Mordehai, J. Cai, Anal. Chem. 66 (1994) 2103.
- [9] A. von Brocke, G. Nicholson, E. Bayer, Electrophoresis 22 (2001) 1251.
- [10] M. Albin, P.D. Grossman, S.E. Moring, Anal. Chem. 65 (1993) 489A.
- [11] G. Hempel, Electrophoresis, 21 (2000) 691.
- [12] C.-X. Zhang, W. Thormann, Anal. Chem. 68 (1996), 2523.
- [13] N.J. Reindhoud, A.P. Tinke, U.R. Tjaden, W.M.A. Niessen, J. van der Greef, J. Chromatogr. 627 (1992) 263.
- [14] A.J. Tomlison, L.M. Benson, S. Jameson, D.H. Johnson, S. Naylor, J. Am. Soc. Mass. Spectrom. 8 (1997) 15.
- [15] F. Kvasnička, M. Jaroš, B. Gaš, J. Chromatogr. 916 (2001) 131.
- [16] G. Hempel, D. Lehmkuhl, S. Krüpelmann, G. Blaschke, J. Boos, J. Chromatogr. A 745 (1996) 173.
- [17] J. Olgemöller, G. Hempel, J. Boos, G. Blaschke, J. Chromatogr. B 726 (1999) 261.
- [18] J.P. Chevret, R.E.J. Van Soest, M. Ursem, J. Chromatogr. 543 (1991) 439.
- [19] A. Mainka, K. Bächmann, J. Chromatogr. A 767 (1997) 241.
- [20] T. Wang, J.H. Aiken, C.W. Huie, R. A. Hartwick, Anal. Chem. 63 (1991) 1372.
- [21] T. Tsuda, J.V. Sweedler, R.N. Zare, Anal. Chem. 62 (1990) 2149.
- [22] T.J. Thompson, F. Foret, P. Vouros, B.L. Karger, Anal. Chem. 65 (1993) 900.

- [23] A.J. Tomlison, L.M. Benson, S. Jameson, D.H. Johnson, S. Naylor, *J. Am. Soc. Mass. Spectrom.* 8 (1997) 15.
- [24] Q. Yang, A.J. Tomlison, S. Naylor, *Anal. Chem.* 71 (1999) 183A.
- [25] C.J. Herring, J. Qin, *Rapid Commun. Mass Spectrom.* 13 (1999) 1.
- [26] D. Figeys, G.L. Corthals, B. Gallis, D.R. Goodlett, A. Ducret, M.A. Corson, R. Aebersold, *Anal. Chem.* 71 (1999) 2279.
- [27] Ch.-X. Zhang, W. Thormann, *Anal. Chem.* 68 (1996) 2523.
- [28] A.B. Wey, Ch.-X. Zhang, W. Thormann, *J. Chromatogr. A* 853 (1999) 95.
- [29] J. L. Beckers, P. Boček, *Electrophoresis* 21 (2000) 2747.
- [30] D.L.D. Deforce, F.P.K. Ryniers, E.G. Van den Eeckhout, F. Lemièrè, E.L. Esmans, *Anal. Chem.* 68 (1996) 3575.
- [31] T. Stroink, E. Paarlberg, J.C.M. Waterval, A. Bult, W.J.M. Underberg, *Electrophoresis* 22 (2001) 2374.
- [32] M. Larsson, E.S.M. Lutz, *Electrophoresis* 21 (2000) 2859.
- [33] J. Gysler, M. Mazereeuw, B. Helk, M. Heitzmann, U. Jaehde, W. Shunack, U.R. Tjaden, J. van der Greef, *J. Chromatogr. A* 841 (1999) 63.
- [34] J.M. Hille, A.L. Freed, H. Wätzig, *Electrophoresis* 22 (2001) 4035.
- [35] J. Wei, C.S. Lee, I.M. Lazar, M.L. Lee, *J. Microcol. Sep.* 11 (1999) 193.
- [36] Q. Tang, A.K. Harrata, C.S. Lee, *Anal. Chem.* 69 (1997) 3177.
- [37] P.G. Righetti, C. Gelfi, M. Conti, *J. Chromatogr. B* 699 (1997) 91.

CHAPTER II

INSTRUMENTATION AND EXPERIMENTAL PROCEDURES

Instrumentation, equipment and several experimental approaches were common to all studies carried out. These are described in the following sections.

II.1. CAPILLARY ELECTROPHORESIS WITH UV DETECTION

A commercial Crystal CE Model 300 (UNICAM, Madison, WI, USA) capillary electrophoresis apparatus with a four-vial moving tray was used for all separations. This instrument is capable of performing both electrokinetic and hydrodynamic injections, applying pressure and voltage simultaneously, and producing both positive and negative pressures. The separation columns were thermostated during runs to a temperature value close to room temperature (22-25 °C). For separations with UV/Vis detection, a Model 759 A UV absorbance detector (Applied Biosystems, Foster City, CA, USA) was used. ChromPerfect 3.54 Data Acquisition software (Justice Laboratory Software, Palo Alto, CA, USA) was used to collect data from the UV detector.

II.2. COLUMN COATING

In order to achieve a complete separation for each group of investigated compounds, it was necessary to suppress the electroosmotic flow in the separation column by modifying the capillary wall. Although other coating procedures were tested, a polyvinyl alcohol (PVA) coating procedure was the easiest, most straightforward to use,

and produced consistently stable and durable coatings that provided good separations; this method was therefore used throughout this work.

Fused silica capillaries of various internal and external diameters (Polymicro Technologies, Phoenix, AZ, USA) were coated with PVA prior to use to suppress the electroosmotic flow. The procedure was similar to that used by Clarke et al. [1]. Briefly, a solution of 6% PVA in boiling water was thoroughly degassed using sonication and then centrifuged ($1500\times g$, 5 min) to remove undissolved PVA. Then the fused silica capillary (2-3 m in length) was attached to a small in-house made pressure vessel containing a vial with the 6% PVA solution. The PVA solution was passed through the capillary column at 100 psi for 1 h. The column was then emptied at 30 psi and dried under nitrogen for 1 h. Finally, the column was placed in a GC oven (HP 5890, Hewlett-Packard, Palo Alto, CA, USA) under a stream of nitrogen (20 psi) and subjected to a temperature program of 40 °C ramped to 145 °C at 5 °C min⁻¹, and then maintained at 145 °C for 5 h. The entire process was repeated while filling the capillary from the opposite end to ensure sufficient and uniform coating.

II.3. TIME-OF-FLIGHT MASS SPECTROMETER

A commercial Jaguar™ TOFMS (LECO, St. Joseph, MI, USA) with orthogonal extraction was used as a detector in this work. TOFMS has several advantages over scanning mass spectrometers such as ion trap, quadrupole, and sector instruments. Instead of scanning the mass range, TOFMS acquires the signal for all m/z values simultaneously. Thus, a complete mass spectrum can be generated with each pulsed ion extraction.

The Jaguar™ TOFMS uses a heated nitrogen curtain gas moving counter to the flow of ions into the mass spectrometer to desolvate ions emerging from the electrospray tip. After desolvation at atmospheric pressure, ions are carried through a nozzle, skimmer and an RF-quadrupole to the ion pulsing region ($\sim 2 \times 10^{-6}$ mbar). In this region, a portion of the ion beam receives a pulse of kinetic energy applied orthogonally to the direction of the ion beam. The pulsing is performed at rates as high as 5 kHz, allowing the TOFMS to generate mass spectra at rates much faster than scanning mass spectrometers. The ions then separate according to differences in their m/z ratios as they travel the length of the flight tube, and are subsequently detected using a microchannel plate (MCP) and multi-anode detector. The Jaguar™ TOFMS can record, sum, and store complete mass spectra at rates as high as 100 summed spectra s^{-1} . In addition to speed, other characteristics of TOFMS, such as high duty cycle, high ion transmission, and ease of peak deconvolution using the selected-ion monitoring feature of the SprayTOF software (LECO, St. Joseph, MI, USA) make TOFMS an ideal detector for complex samples and extremely narrow peaks produced by fast separations or when trace compounds are analyzed by ITP.

All experiments were performed in the positive ion mode. For each group of compounds, the front end voltages (ion optics) were adjusted to give the highest overall signal, while the flight tube voltages were left without modification. The voltages were adjusted manually on the interface, nozzle, skimmer, quadrupole high, quadrupole low, quadrupole exit, quadrupole RF, vertical (V) deflect, horizontal (H) deflect, focus, Einzel V-deflect, Einzel H-deflect, and Einzel focus as the analytes were continually infused into the mass spectrometer.

II.4. ELECTROSPRAY INTERFACE

The transfer of sample between the separation column and the TOFMS was accomplished by electrospray ionization (ESI). The ESI interface is the most commonly used interface for coupling electrophoretic techniques to MS [2] due to some of its inherent advantages: high ionization efficiency (50-100%), ability to produce multiply charged ions, which reduces the m/z ratio to fit the operational range of the MS instrument (which is especially crucial for the analysis of larger biomolecules) and the ability to bring ions directly from the liquid phase into the gas phase.

There are two general types of ESI interfaces: sheath-flow and sheathless [3-6]. Sheath-flow configurations use either coaxial tubing [7] or a liquid junction [8] to introduce the flow of make-up liquid. The coaxial sheath-flow configuration has several advantages, including simple fabrication, reliability, robustness and versatility, which makes it the most widely used CE-MS interface [3], despite the fact that its sensitivity is lower than that of sheathless electrospray [2,3,9,10]. Also, unlike sheathless interfaces, the coaxial sheath interface can be used with capillaries that have very low or completely suppressed electroosmotic flow, which is another advantage, and was a major consideration for this work.

Therefore, a liquid sheath electrospray interface, built in-house [11], was used for coupling the electrophoretic separation to the TOFMS (see Figure II.1). The liquid sheath flow rate was controlled using a syringe pump (Model 11, Harvard Apparatus, Holliston, MA, USA) with a 250- or 500- μL glass Gastight[®] syringe fitted with a two-inch stainless steel needle (Hamilton, Reno, NV, USA). The syringe was connected to a 50 μm i.d. \times 187 μm o.d. fused silica capillary transfer line (Polymicro Technologies,

Phoenix, AZ, USA) using a Chemfluor® Teflon straight union (Norton Performance Plastics, Akron, OH, USA). A Chemfluor® tee connected the transfer line to the analytical CE column. As the liquid sheath entered the tee, it flowed along the outside of the CE column and inside the stainless steel electrospray needle, which was held by the tee. To allow for better focusing of the electrospray voltage, and thus form a higher electric field on the tip which ultimately aids the formation of ions, the capillary outlet end was ground to a sharp tip using a 9- μm diamond grit paper mounted on a rotating disc.

The column end extended approximately 0.5 mm beyond the edge of the stainless steel electrospray needle. The needle was positioned approximately 0.5-1.0 cm from the TOFMS interface plate. The ESI interface was mounted on an XYZ-stage (Series 462, Newport, Englewood, CO, USA) used to optimize the electrospray needle position relative to the TOFMS sample orifice. A microscope fitted with a 20 \times eyepiece and a 15-60 \times adjustable objective (Edmund Scientific, Barrington, NJ, USA) was used together with a Series 41722 fiber optic illuminator (Cole-Palmer, Arcade, NY, USA) to visually observe the integrity of the Taylor cone at the electrospray tip.

A commercial direct infusion electrospray interface (LECO, St. Joseph, MI, USA) with a 20- μm i.d. fused silica spray capillary was used to acquire the mass spectra of the analytes.

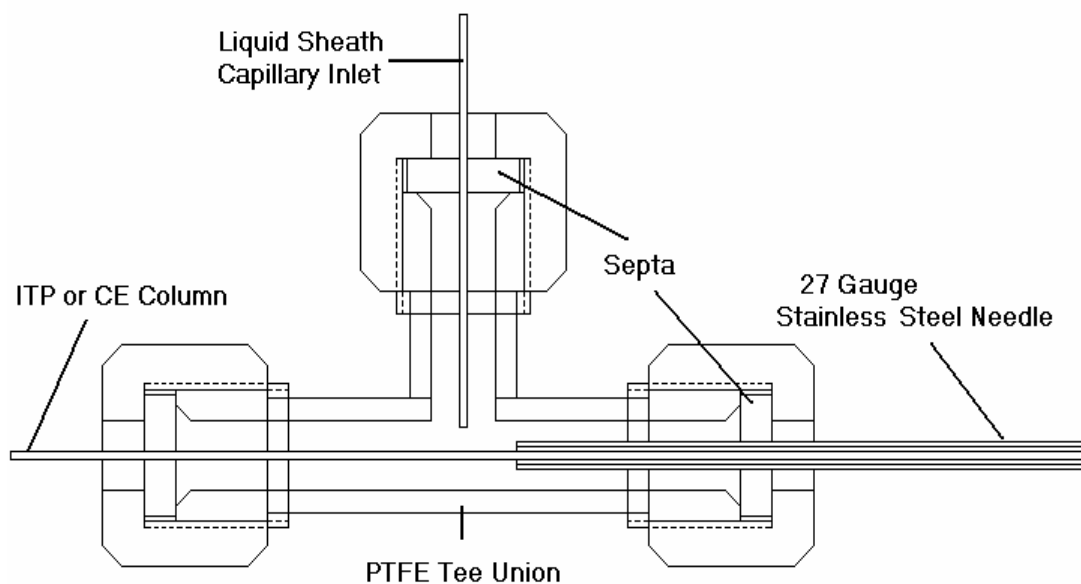

Figure II.1. Liquid sheath electrospray interface.

II.5. COMPREHENSIVE ISOTACHOPHORESIS-CAPILLARY ELECTROPHORESIS.

The instrumentation and methodology for ITP-CE used in this work were described in detail previously [12]. Briefly, the ITP-CE instrument consisted of a Valco (Houston, TX, USA) Model C22 four-port manually actuated sample valve (10 μ L sample loop) connected to both the ITP column and the tailing electrolyte (TE) reservoir with a platinum electrode attached to a Spellman (Hauppauge, NY, USA) 60 kV/500 μ A SL60PN30 high voltage power supply. A custom made quartz tee (365 μ m i.d., InnovaQuartz, Phoenix, AZ, USA) was used at the bifurcation point between the ITP and CE columns to minimize dead volume and residual flow effects after leading electrolyte

(LE) counterflow infusion. A UV 300 UV/Vis detector (ThermoQuest, San Jose, CA, USA) was positioned just before the bifurcation point to signal when the ITP stack arrived at the junction between the ITP and CE columns prior to infusion of the LE counterflow from a Harvard Apparatus (Holliston, MA, USA) Model 22 syringe pump.

II.6. SOLID PHASE EXTRACTION

Due to the complexity of the matrix of many biological specimens and due to the low concentrations of the analytes of interest, a pre-separation work-up of the sample becomes in many cases an essential part of a successful assay. As for the techniques described here, both electrophoretic separations and electrospray ionization-TOFMS detection are very sensitive to the presence of high, physiologic concentrations of salts in the analyzed specimen. Therefore, along with minimizing the amount of interferences, reducing the salt content of the sample was important for the success of the developed assays.

The most popular method for sample preparation today is solid phase extraction (SPE) [13]. SPE refers to the nonequilibrium, exhaustive removal of chemical constituents from a flowing liquid sample via retention on a contained solid sorbent and subsequent recovery of selected constituents by elution from the sorbent [14].

Although SPE was introduced to the commercial market in the late 1970s, it was not until the early 1990s that improvements in formats and development of new sorbents facilitated the replacement of many labor-intensive liquid-liquid extraction (LLE) sample preparation techniques with the more sophisticated SPE methods [13]. Using SPE in place of LLE has many advantages. SPE is faster and requires less manipulation, which

reduces analysis time and labor. The consumption and subsequent disposal of organic solvents is also reduced, [15] which results in reduced analyst exposure to organic solvents and lower costs. With SPE, the productivity increases significantly because multiple simultaneous extractions can be performed making automation possible. SPE provides higher concentration factors than LLE [15] and can be used to store analytes in an adsorbed state or to immobilize analytes for chemical derivatization [16]. SPE is a multistage separation technique providing greater opportunity for selective isolation than LLE [15,17], such as fractionation of the sample into different compounds or groups of compounds by varying elution conditions[16].

An SPE method usually consists of four steps. Prior to sample application, the SPE device is conditioned to ensure reproducible retention of the compound of interest (the isolate). Then sample is applied and the isolate is retained by the sorbent along with other components of the matrix. The SPE device is then rinsed with a solvent which removes as many unwanted matrix components as possible. Finally, the isolate is eluted by a solvent which ideally removes the compound of interest while leaving the remaining matrix constituents not removed in the rinse step.

Currently, there is a large variety of sorbents available from more than 50 manufacturers. These include the classic polar silica, alumina, and magnesium silicate solid phases, as well as bonded silica, graphitized carbon sorbents, both functionalized and apolar polymeric resins, based on highly cross-linked polystyrene-divinylbenzene (PS-DVB), ion-exchange sorbents, controlled-access sorbents, immunoaffinity sorbents, and molecularly imprinted polymers [14]. The SPE sorbents are commercially available in three formats: contained within cartridges, in syringe barrel columns, or in disks.

Recently, coated 96-well plates, ideal for parallel processing with robotic automated workstations, became commercially available.

In this work, SPE columns with two types of sorbents were utilized: reversed phase C18-modified silica and an innovative PS-DVB based mixed-mode cation exchanger. Mixed-mode sorbents are designed to utilize both primary and secondary retention mechanisms to capture an analyte or a group of analytes. This is done by chemically producing multiple retention sites on an individual particle. These sorbents exploit interaction with different functional groups on a single analyte or different functional groups on multiple analytes. Mixed-mode SPE sorbents are particularly useful for the extraction of analytes from bodily fluids [15].

The next three chapters apply the instrumentation and methods described in this chapter to specific analytical problems. Each chapter evaluates these approaches for the measurement of a single family of compounds important in clinical diagnosis, each family related broadly to differing etiologies for hypertension.

II.7. REFERENCES

- [1] N.J. Clarke, A.J. Tomlison, G. Schomburg, S. Naylor, *Anal. Chem.* 69 (1997) 2786.
- [2] J.T. Whitt, M. Moini, *Anal. Chem.* 75 (2003) 2188.
- [3] M. Moini, *Anal. Chem.* 73 (2001) 3497.
- [4] J. Cai, J. Henion, *J. Chromatogr. A* 703 (1995) 667.
- [5] S.N. Krylov, N.J. Dovichi, *Anal. Chem.* 72 (2000) 111R.

- [6] J. Ding, P. Vouros, *Anal. Chem.* 71 (1999) 378A.
- [7] R.D. Smith, C.J. Barinaga, H.R. Udseth, *Anal. Chem.* 60 (1988) 1948.
- [8] E.D. Lee, W. Muck, J.D. Henion, T.R. Covey, *Biomed. Environ. Mass Spectrom.* 18 (1989) 844.
- [9] G.M. Janini, T. P. Conrads, K.L. Wilkens, H.J. Isaaq, T.D. Veenstra, *Anal. Chem.* 75 (2003) 1615.
- [10] J.F. Kelly, L. Ramaley, P. Thibault, *Anal. Chem.* 69 (1997) 51.
- [11] D. C. Collins, Q. Tang, N. Wu, M.L. Lee, *J. Microcol. Sep.* 12 (2000) 442.
- [12] C. R. Bowerbank, M.L. Lee, *J. Microcol. Sep.* 13 (2001) 361.
- [13] M.-C. Henion, *J. Chromatogr. A* 856 (1999) 3.
- [14] M.J.M. Wells, in S. Mitra, ed., *Sample Preparation Techniques in Analytical Chemistry*, Wiley, Hoboken, NJ, Ch. 2.
- [15] J.S. Fritz, M. Macka, *J. Chromatogr. A* 902 (2000) 137.
- [16] C.W. Huck, G.K. Bonn, *J. Chromatogr. A*, 885 (2000) 51.
- [17] M.J. Wells, J.L. Michael, *Anal. Chem.* 59 (1987) 1739.

CHAPTER III

DETERMINATION OF CATECHOLAMINES AND METANEPHRINES IN URINE BY CAPILLARY ELECTROPHORESIS/ELECTROSPRAY IONIZATION/TIME-OF-FLIGHT MASS SPECTROMETRY

III.1. INTRODUCTION

Catecholamines represent a class of low molecular weight, potent bioregulatory molecules. They act as neurotransmitters in the central and peripheral nervous systems and serve as hormones in the systemic circulation, regulating heart rate and blood pressure [1].

Clinical measurements of plasma or urine levels of catecholamines and their metabolites, metanephrines, are crucial for the proper diagnosis and treatment of certain potentially fatal catecholamine-producing tumors, e.g., pheochromocytoma [1]. Most current clinical assays for catecholamines and metanephrines use HPLC with electrochemical detection [2-6]. However, these assays are not completely specific and can also suffer from insufficient sensitivity.

In the last few years, the coupling of various separation techniques to mass spectrometry has become a focus of substantial research. The mass spectrometer can identify the analytes based on their mass-to-charge ratios and thus provide the detection specificity that most other types of detectors lack. GC-MS has been used for the quantitation of urinary normetanephrine and metanephrine [7]. Recently, some authors reported the application of HPLC-MS to the analysis of 9-fluorenylmethyloxycarbonyl

derivatives of catecholamine standards [8] and underivatized catecholamines and metanephrines in a spot collection of urine [9]. Kushnir et al. have recently published an HPLC-MS/MS method for the determination of catecholamines in patient specimens (24-h urine collection) [10].

Applications of other separation methods for the analysis of catecholamines have been proposed, namely electrophoretic techniques offering higher resolution than HPLC. While there have been many papers reporting the use of capillary electrophoresis (CE) with UV or fluorescence detection for the determination of metanephrines and/or catecholamines [11-18], very few authors have used CE-MS for the analysis of these compounds [19-22]. Three of these reports were limited to analysis of solutions of standard compounds [18,19,22]. Jäverfalk-Hoyes et al. analyzed an extract of brain tissue, however, dopamine was the only catecholamine assayed [21]. To our knowledge, assays employing electrophoretic separation coupled with MS detection have not been applied to the simultaneous determination of catecholamines and metanephrines in human urine or plasma.

In this study, I have sought to combine the advantages of the high separation efficiency of capillary electrophoresis (CE) and the specificity of TOFMS detection for the development of a method for simultaneous determination of catecholamines and metanephrines. I have applied the developed method to the determination of analytes of interest in a spot collection of human urine with concentrations within the reference interval for healthy individuals [1]. Patients with pheochromocytoma have concentrations at least double those of healthy individuals and commonly have

concentrations more than 10 times the upper limit of the reference interval [1]. Sample cleanup was performed by solid phase extraction (SPE) on cation-exchange sorbents.

III.2. EXPERIMENTAL

III.2.1. Materials and chemicals

Catecholamines and their O-methoxylated metabolites (3-hydroxytyramine HCl (dopamine, D), 3-methoxytyramine HCl (3MT), (\pm)-norepinephrine[+]-hydrogentartrate (NE), DL-normetanephrine HCl (NM), (\pm)-epinephrine HCl (E), and DL-metanephrine HCl (M)) were purchased from Sigma (St. Louis, MO, USA). Internal standards (3,4-hydroxybenzylamine HBr (DHBA) and 4-hydroxy-3-methoxybenzylamine HCl (HMBA)) were purchased from Aldrich (Milwaukee, WI, USA). Ammonium acetate, sodium acetate, HPLC-grade methanol and glacial acetic acid were from Mallinckrodt (Paris, KY, USA). HPLC grade water (pH 5.2) was obtained from Fisher (Fair Lawn, NJ, USA) and was used for the preparation of all solutions used in this work. Fused silica capillaries (75 μm i.d. \times 365 μm o.d. and 50 μm i.d. \times 187 μm o.d., Polymicro Technologies, Phoenix, AZ, USA) were coated with polyvinyl alcohol (PVA, 99+%, average MW 89,000-98,000 g/mol) from Aldrich (Milwaukee, WI, USA) as described in Chapter II.

III.2.2. Buffers and standard solutions

Ammonium acetate and sodium acetate buffers were prepared at 30 mM concentration and adjusted to a final pH of 4.2 - 4.5 with 10% acetic acid. Acetic acid (1%) was prepared by mixing glacial acetic acid with water in a ratio of 1:99 (v/v). All

buffers were filtered using Acrodisc[®] syringe filters with 0.2 μm HT Tuffryn[®] membrane (Pall Gelman Laboratory, Ann Arbor, MI, USA) and degassed by sonication. Stock solutions of D, NE, E, NM, M, HMBA, and DHBA were prepared in 0.1 M acetic acid at 10 mM and were kept in the dark at $-20\text{ }^{\circ}\text{C}$. Under these conditions, the solutions were stable for at least one month. The stock solutions were thawed and further diluted to the desired concentrations with water immediately prior to use.

III.2.3. Instrumentation

The following combination of instrumentation was used for these studies. Crystal CE Model 300 (UNICAM, Madison, WI, USA) capillary electrophoresis apparatus was used for all separations. Separation columns were thermostated to $22\text{ }^{\circ}\text{C}$. For separations with UV/Vis detection, a Model 759 A UV absorbance detector (Applied Biosystems, Foster City, CA, USA) was used. ChromPerfect 3.54 Data Acquisition software (Justice Laboratory Software, Palo Alto, CA, USA) was used to collect data from the UV detector. A commercial Jaguar[™] TOFMS (LECO, St. Joseph, MI, USA) with an in-house built liquid sheath electrospray interface was used as the MS detector. MS data were collected with a sum rate of 1600, which resulted in $3.1\text{ spectra s}^{-1}$. The nozzle board was heated to $80\text{ }^{\circ}\text{C}$. All instrumentation used in this work is described in detail in Chapter II.

III.2.4. Solid phase extraction

A modified Waters Generic Oasis MCX method for extraction of basic compounds was used. Urine samples collected from healthy volunteers were acidified

with HCl to pH 2 and centrifuged at $1600 \times g$ for 3 min. To 2- and 5-mL aliquots of urine, 100 μL of 0.2 M EDTA/mL of urine and 10 μL of 0.5 M ascorbic acid/mL of urine were added. For CE-UV comparison of spiked and non-spiked urine samples, some of the 2-mL aliquots were enriched with catecholamine and metanephrine standards to a final concentration of 5 μM . For MS detection, 5-mL aliquots of urine were spiked with 50 μL of 100- μM internal standard (DHBA) to give a final concentration of 1 μM . The specimens were adjusted to pH 7 with sodium hydroxide and immediately applied to the SPE cartridge. One-mL Oasis MCX cartridges filled with 30 mg of sorbent (Waters, Milford, MA, USA) were conditioned with 1 mL of methanol and 1 mL of water. After sample application, the cartridges were washed with 1-2 mL of 0.1 M HCl and 1-2 mL of methanol. The analytes were eluted with 1.4 mL of 5% ammonium hydroxide in methanol into vials containing 30 μL of glacial acetic acid. The eluates were dried using vacuum centrifugation and reconstituted in 200 μL (for the 2-mL urine aliquots) or 250 μL (for the 5-mL urine aliquots) of water.

III.2.5. Recovery studies

Human urine samples supplemented with catecholamine and metanephrine standards at concentrations of 10 and 2 μM ($n=6$) and samples without the addition of standards were used to evaluate extraction recoveries. All samples were extracted by SPE and analyzed by CE-UV at the same time. The analyte signal from the non-spiked samples was subtracted from the average analyte signal from the supplemented samples and the recovery was calculated by comparing the difference between the spiked and

non-spiked samples to the signal of a mixture of standards of corresponding concentrations.

III.2.6. Linearity, detection limits, and quantitation

For UV detection, linearity was evaluated by analyzing solutions of individual catecholamines and metanephrines at concentrations of 0.5, 1.0, 10.0, and 100.0 μM . The limits of detection (LOD) were determined as the concentrations corresponding to a signal-to-noise ratio (S/N) of 3. The noise was determined as the root mean square (RMS) noise using ChromPerfect 3.54 Data Acquisition software. The concentrations were calculated using the calibration curves constructed from the linearity study data for each individual analyte. For MS detection, because of the dependence of electrokinetic injection on the ionic strength of the sample matrix, an internal standard was used instead of a calibration curve for determining the concentrations of the analytes. The LOD's were determined by analyzing mixtures of catecholamines and metanephrines of progressively lower concentrations until the signal of each analyte was $3 \times$ the S/N ratio. The concentrations of the analytes, C_{anal} , were calculated using the following equation:

$$C_{\text{anal}} = [\text{Signal}_{\text{anal}}/(\text{RIA}_{\text{anal}} \times \text{Recovery}_{\text{anal}})]/[(\text{Signal}_{\text{IS}}/(\text{RIA}_{\text{IS}} \times \text{Recovery}_{\text{IS}}))] \times C_{\text{IS}}, \quad (\text{III.1})$$

where $\text{Signal}_{\text{anal}}$ and $\text{Signal}_{\text{IS}}$ are the peak areas of the analytes and the internal standard, respectively, RIA_{anal} and RIA_{IS} are the relative ion abundancies, $\text{Recovery}_{\text{anal}}$ and $\text{Recovery}_{\text{IS}}$ are the SPE recoveries, and C_{IS} is the concentration of the internal standard.

III.3. RESULTS AND DISCUSSION

III.3.1 CE separation of catecholamines and metanephrines

The conditions for the electrophoretic separation of the analytes were chosen with the limitations posed by ESI-MS detection in mind. Electrospray ionization requires the use of volatile buffers free of any non-volatile additives. However, most catecholamine and metanephrine separations reported in the literature [11-18] used such additives to achieve good separation or to protect the analytes from degradation. In lower pH buffers, in which the compounds have a net positive charge, either micelle-forming surfactants [11] or electroosmotic flow (EOF)-decreasing wall modifiers [18] have been used to separate the analytes. High pH buffers, in which the compounds have a net negative charge, yield more favorable separation conditions. However, because the compounds are less stable and easily oxidized under basic conditions, non-volatile antioxidants have often been used [12-17].

Using CE-UV, I evaluated 30 mM sodium acetate and ammonium acetate buffers, both at pH 4.2 - 4.5, as well as 1% acetic acid for the separation of a standard mixture of eight compounds consisting of three catecholamines, three methanephrines, and two internal standards. The resolution achieved with acetic acid was lower than that obtained with the acetate buffers, nevertheless all compounds were baseline resolved. To avoid using EOF-reducing buffer additives, I permanently coated the capillary inner wall with polyvinyl alcohol (PVA). This coating markedly reduced the EOF and significantly improved the separation (see Figure III.1). Additionally, it was easy to apply and was stable after application, providing good reproducibility.

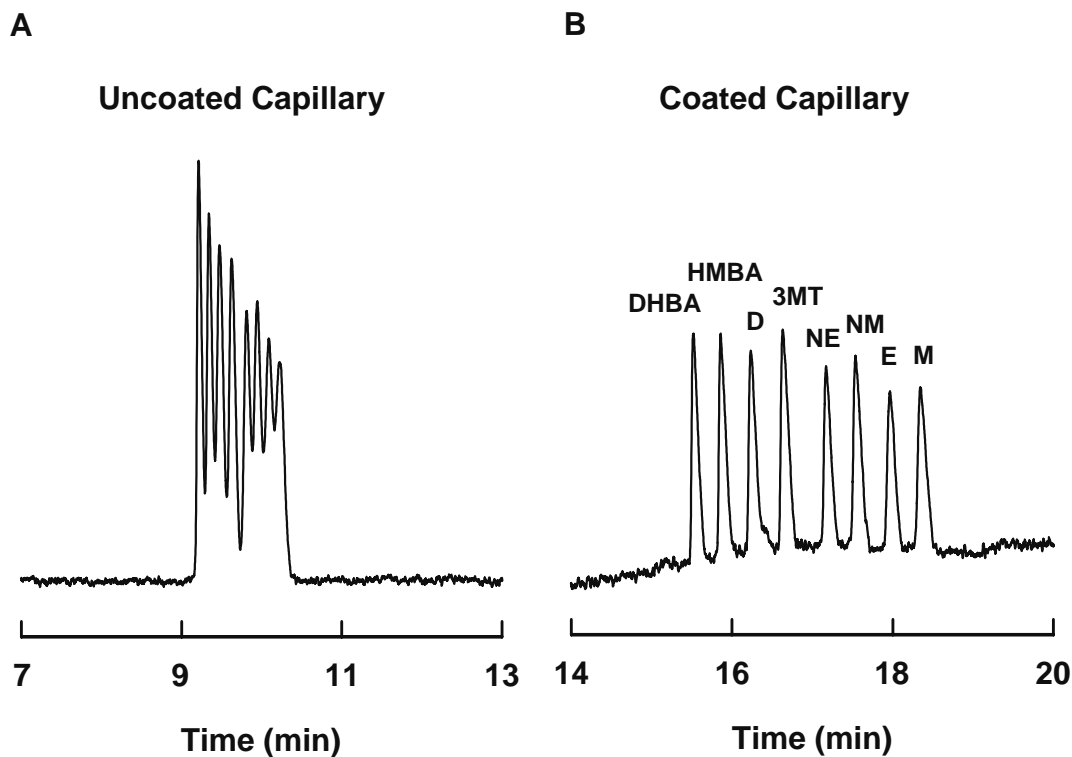

Figure III.1. CE-UV separation of 1 μM catecholamine standards on (A) uncoated and (B) PVA-coated capillaries. Conditions: buffer, 1% acetic acid (pH 2.8); capillary, (80+12) cm, 75 μm i.d., 360 μm o.d.; injection, 0.1 min at 20 kV; run voltage, 25 kV; current, 8.8 μA ; $\lambda=215$ nm.

The linearity of the CE-UV of catecholamines and metanephrines was determined in the range of 0.5 – 100 μM from three replicate measurements. The limits of detection (LOD) were determined as concentrations corresponding to $S/N = 3$. The correlation coefficients, R (range), regression equations, and LOD's are listed in Table III.1.

Table III.1. Correlation coefficients (R (range)), regression equations, and detection limits (LOD) for CE-UV of catecholamine and metanephrine standards.

Compound	Regression Equation	R (0.5-100 μ M)	LOD (μ M)
DHBA	$y = 868x + 88$	0.9995	0.11
HMBA	$y = 948x + 81$	0.9999	0.10
D	$y = 974x + 50$	0.9996	0.11
3MT	$y = 1069x + 137$	0.9995	0.10
NE	$y = 874x + 169$	0.9999	0.12
NM	$y = 1064x + 140$	0.9999	0.10
E	$y = 1008x + 176$	0.9999	0.11
M	$y = 1136x + 193$	0.9999	0.11

III.3.2. CE-TOFMS analysis of standard compounds

The same standard mixture was analyzed using CE coupled to the TOFMS with electrospray ionization. Ammonium acetate and sodium acetate buffers that had worked well for CE-UV separation were found to suppress ionization of the analytes in the electrospray. I, therefore, used 1% acetic acid as the separation medium. It yielded a stable electrospray and baseline separation of the analytes (see Figure III.2). For CE-UV, 75 μ m i.d./360 μ m o.d. capillaries were used to maximize the signal magnitude without compromising the separation efficiency; for CE-MS, I chose a capillary of a smaller o.d. to achieve a smaller electrospray tip area. This allowed for a better focusing of the electrospray voltage and higher electric field on the tip, ultimately aiding the formation of ions. I had the choice between 50/187 and 75/150 (i.d./o.d. in μ m) capillaries. The 50

μm i.d. was chosen over the 75 μm i.d., because the 50/187 capillary has a thicker wall than the 75/150 capillary and is therefore more resistant to breaking in the presence of accidental gas bubbles formed within the capillary.

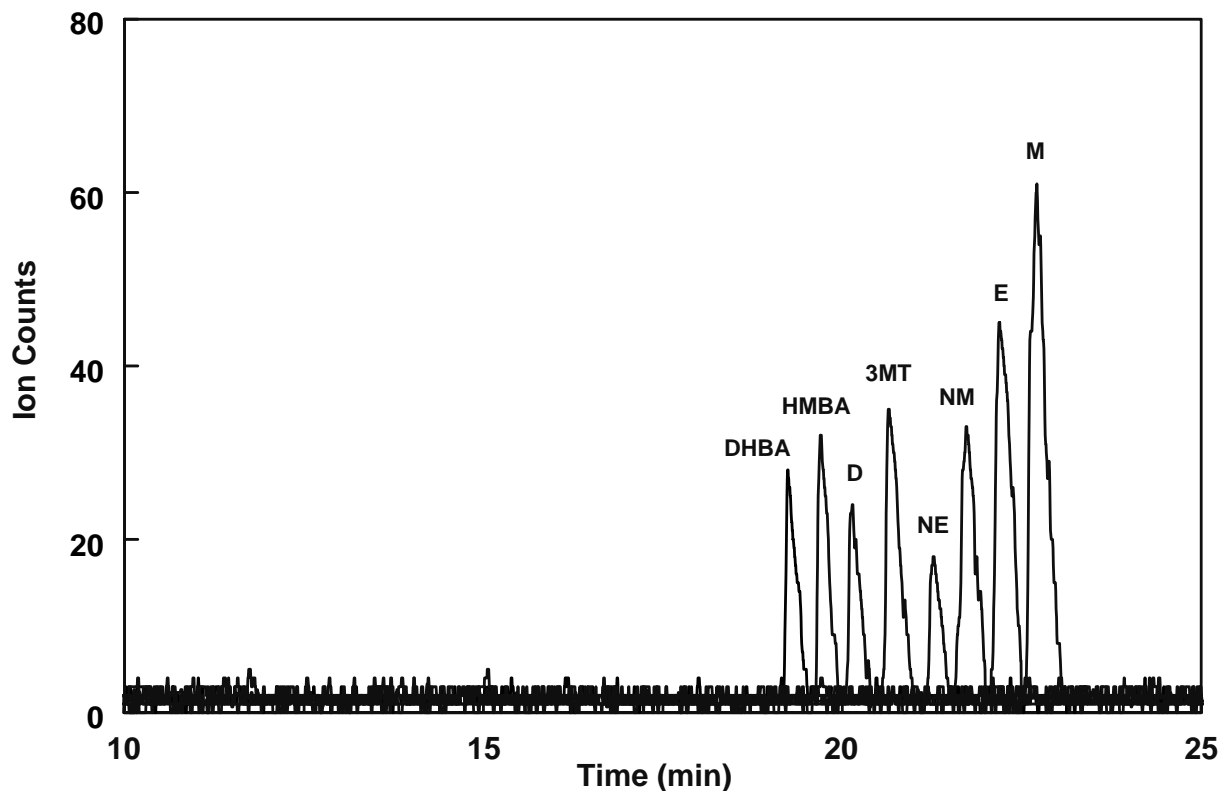

Figure III.2. CE-TOFMS analysis of 1 μM catecholamine standards. CE conditions: buffer, 1% acetic acid (pH 2.8); capillary, 91 cm length, 50 μm i.d., 187 μm o.d., PVA coated; injection, 0.2 min at 20 kV; run voltage, 23 kV; current, 3.0 μA . MS conditions: ES voltage, 3.1 kV; liquid sheath flow and composition, 1.5 $\mu\text{L}/\text{min}$, 75:25:0.1 methanol/water/acetic acid, (v/v).

Under the experimental conditions used, each of the analytes yielded two types of ions: a protonated molecular ion (see Table III.2) and a daughter ion formed by the loss of either a water molecule or an ammonia molecule from the protonated molecular ion. However, for all of the compounds studied here, the relative abundances of the daughter ions were less than 10 % of the relative abundances of the molecular ions, and thus, detection was based on the signal produced by the molecular ions. The mass resolution was calculated to be 928 at m/z 170.

As observed by other authors [22], the relative abundances of the individual analytes were not equal. For the purposes of quantitation using the CE-MS method, the relative abundances were calculated as ratios of the peak areas of 1- μ M standards of each catecholamine and metanephrine to the peak area of the internal standard.

Due to the inherent dilution of the analyte zones by the liquid sheath as they exited the CE column, the LOD's of this technique were substantially higher than those obtained with a UV detector under the same pressure injection conditions. For a 10- μ M mixture of standards, the signals of four of the compounds (DHBA, HMBA, D, and NE) were only slightly higher than the LOD's obtained using used the maximum pressure injection (1.5 % of the length of the capillary) that still yielded reasonable separation efficiency. (Results not shown.) Therefore, electrokinetic injection was used, which allowed for the introduction of narrow, highly concentrated sample zones into the capillary and, thus, yielded significantly lower LOD's [24,25]. The LOD's were determined by analyzing progressively lower concentrations of catecholamines and metanephrines until the signals of the individual analytes were $3 \times$ the S/N ratio.

Mixtures of the analytes at concentrations 1.0, 0.7, 0.4, 0.3, 0.2, and 0.1 μM were thus analyzed. The detection limits for the analyte standards are summarized in Table III.2.

Table III.2. Mass-to-charge ratios, relative abundances (RA), and CE-MS LOD's of protonated analyte molecular ions.

Compound	m/z (M+1 ions)	RA (%)	LOD's (μM)
DHBA	140.1	100	0.2
HMBA	154.1	114	0.2
D	154.1	86	0.3
3MT	168.1	125	0.2
NE	170.1	71	0.3
NM	184.1	118	0.2
E	184.1	162	0.1
M	198.1	256	0.1

III.3.3. Sample cleanup

Although catecholamines and metanephrines have very similar structures, their chemical behaviors, namely interactions with various SPE sorbents, differ significantly. The catecholamines contain a catechol moiety, whereas in the metanephrines, position three of the benzene ring is methoxylated, which produces significant differences in hydrophobicity and pK_a values between these two groups of compounds. Several papers have described the analysis of both catecholamines and metanephrines in urine [2-5] and plasma [6] using one set of chromatographic conditions; however, in these reports, the two groups of compounds were extracted by separate SPE procedures and the extracts were chromatographed separately. For the SPE of catecholamines, alumina or alumina

followed by a cation exchanger have been used [3,5,6]. Metanephrines have been most frequently extracted using a cation exchanger or a combination of cation and anion exchangers [2-6]. A few papers have reported simultaneous extraction and determination of catecholamines and metanephrines in urine and/or plasma [26-30]. Most of these methods [26-29] employed on- or off-line strong cation exchangers to extract all analytes. The specificity and sensitivity was then achieved by post-column coulometric [26,28,29] or chemical [27] oxidation followed by derivatization of the analytes with a fluorogenic reagent. The setups used for these techniques represent complex, multicomponent systems that require optimization of many parameters. Burke et al. [30] published an HPLC-EC method with an extraction procedure for catecholamines, metanephrines and other metabolites utilizing alumina B and N with a diethylether wash and an ethyl acetate elution. In our hands, this approach was not sufficiently reproducible or efficient. Recently, Chan et al. [9] published a method for coupling HPLC to atmospheric pressure chemical ionization mass spectrometry for simultaneous analysis of catecholamines (D, NE, E) and metanephrines (NM, M) in human urine after SPE on Bio-Rex 70 cation-exchange resin. They applied the developed method to a spot collection of healthy human urine; however they did not attempt any quantitation of the analytes in the specimen.

I have evaluated several solid-phase sorbents using the simple CE-UV setup and determined that the Oasis MXC cation exchange cartridges allowed for simultaneous SPE of all six catecholamines and metanephrines and the two internal standards with good recoveries. The manufacturer's extraction method suggested loading an acidified sample, washing the cartridge with 0.1 M HCl and methanol and eluting the analytes with 5%

ammonium hydroxide in methanol. Under these conditions, peaks for the compounds of interest were completely masked by interfering substances present in urine. I tested another suggested wash step that utilized 5% TEA in methanol. This step should eliminate tertiary and aromatic amines. Using this modification, I obtained a significantly cleaner extract. However, the volume of 5% TEA necessary for adequate reduction of interferences caused analyte losses as high as 10%. By applying samples at several pH values, I found that the interferences decreased with increasing pH. Consequently, I used samples adjusted to pH 7 and obtained a reduction of interferences equal to or better than the results with the TEA wash step, while recoveries of the analytes were not adversely affected. Yet higher sample pH was avoided to prevent analyte degradation.

Recoveries of the analytes from human urine spiked with catecholamine and metanephrine standards at 10 μ M concentrations are summarized in Table III.3.

Table III.3. SPE recoveries of catecholamines and metanephrines from spiked urine samples. Recoveries are given as the mean \pm SD for six sets of experiments.

Compound	Recovery (%)
DHBA	93.2 \pm 4.7
HMBA	93.5 \pm 4.0
D	88.5 \pm 4.7
3MT	89.3 \pm 5.8
NE	85.5 \pm 4.1
NM	92.1 \pm 8.8
E	75.9 \pm 9.4
M	89.3 \pm 3.5

CE-UV analysis of SPE extracts of normal human urine sample before and after spiking with catecholamine and metanephrine standards is shown in Figure III.3.

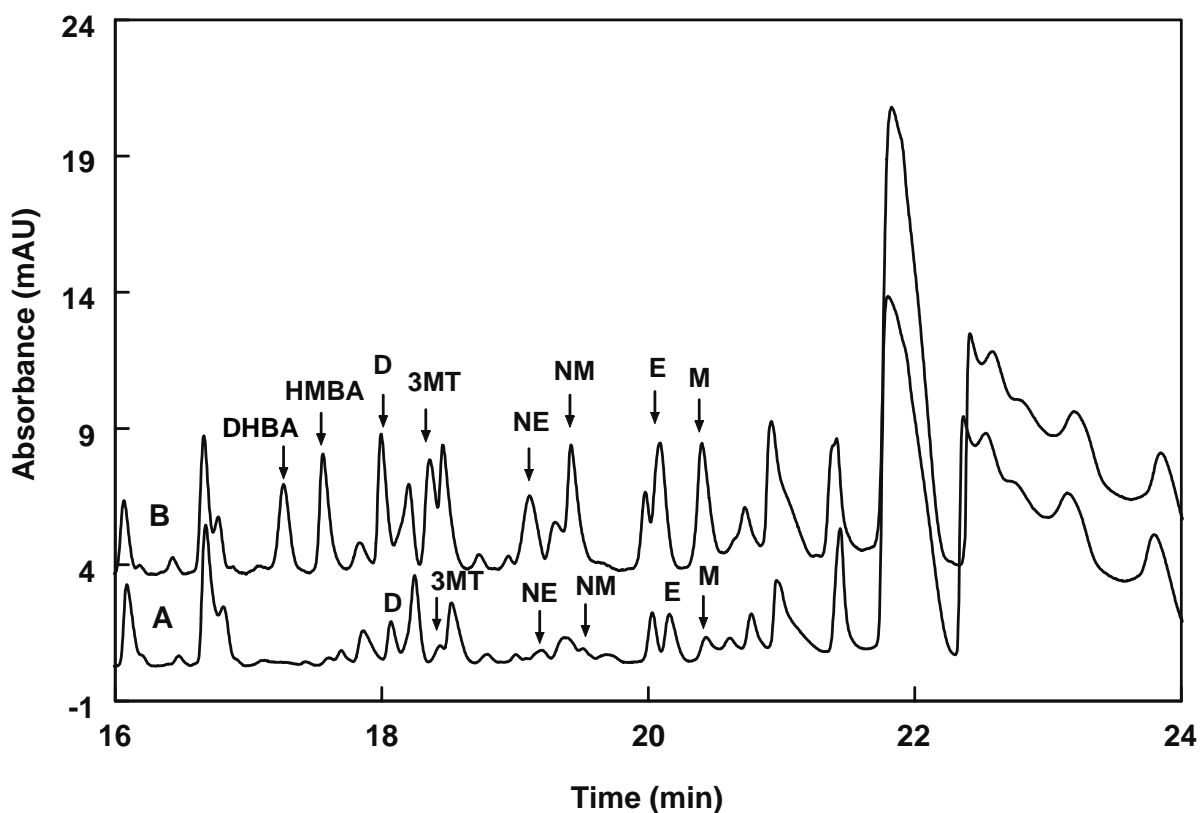

Figure III.3. CE-UV analysis of SPE extracts of 2 mL of (A) blank urine, and (B) urine spiked with catecholamine and metanephrine standards. The extracts were reconstituted in 0.2 mL of water. Conditions: buffer, 30 mM sodium acetate (pH 4.5); capillary, (90+11) cm, 75 μm i.d., 360 μm o.d., PVA coated; injection, 0.2 min at 100 mBar; run voltage, 30 kV; current, 40 μA ; $\lambda=215$ nm.

III.3.4. SPE-CE-TOFMS of catecholamines and metanephrines in urine

Having identified SPE conditions for the catecholamines and metanephrines, urine extracts were analyzed by CE-TOFMS. A selected-ion plot for a representative analysis is shown in Figure III.4. It is clear from Figures III.3 and III.4 that TOFMS detection using selected-ion monitoring yields markedly simplified electropherograms in comparison with non-selective UV detection. The analytes are identified on the basis of their characteristic m/z ratios.

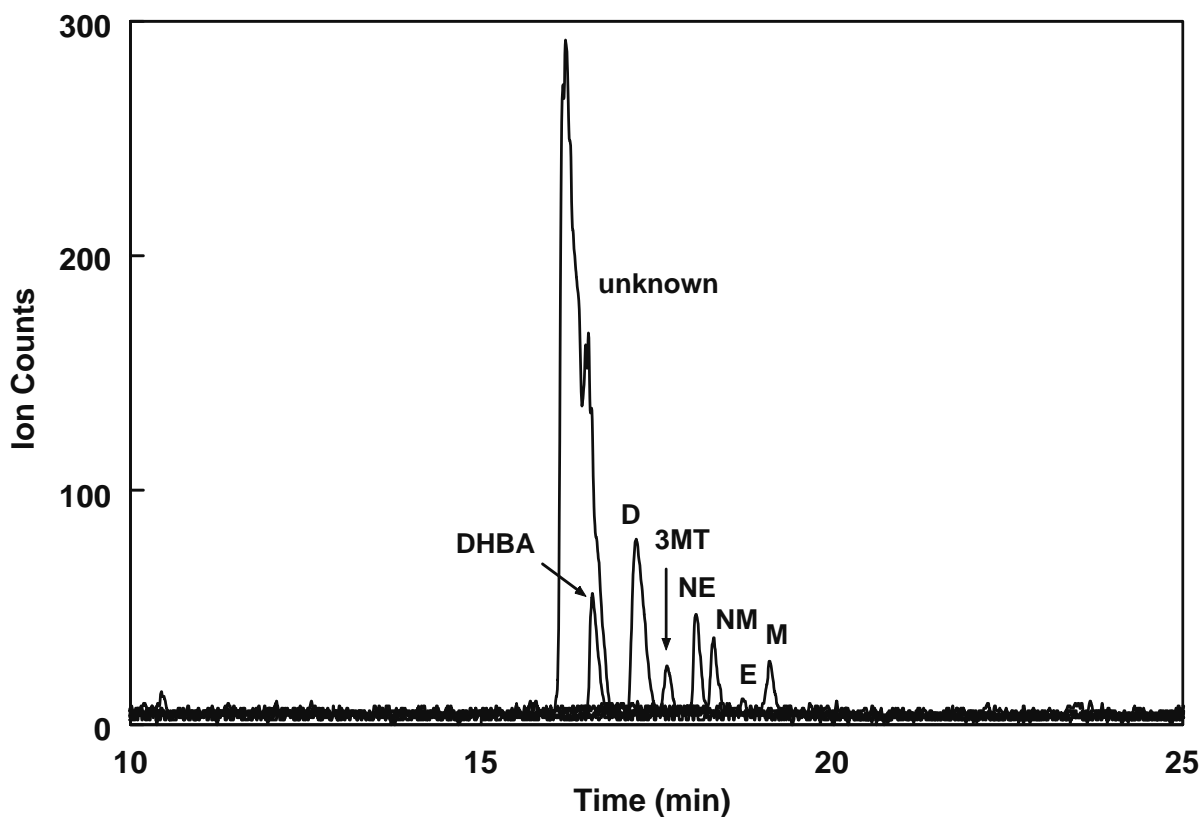

Figure III.4. CE-TOFMS analysis of an SPE extract of 5 mL of non-spiked urine reconstituted in 0.25 mL of water. CE conditions: buffer, 1% acetic acid (pH 2.8); capillary, 86 cm length, 50 μm i.d., 187 μm o.d., PVA coated; injection, 0.2 min at 20 kV; run voltage, 23 kV; current, 3.5 μA . MS conditions as in Figure III.2.

With electrokinetic injection, quantitation is not as straightforward as with pressure injection. The amount injected is influenced by the ionic strength of the sample and, unless the ionic strength is constant, it is not a linear function of the analyte concentration. To solve this problem, I employed an internal standard and calculated the concentrations of the analytes using Equation III.1. I tested two compounds for use as an internal standard, namely DHBA and HMBA. These compounds gave similar ionization efficiencies and SPE recoveries. However, HMBA was ionized with the same m/z ratio as D and migrated next to D, whereas DHBA has a unique m/z ratio and could be easily distinguished from other catecholamines and metanephrines. In order to avoid the possibility of a partial overlap of the peaks of D and HMBA, the two compounds giving ions of the same m/z ratio, DHBA was chosen as the internal standard.

Using this method, I analyzed a 5-mL aliquot of a spot collection of human urine spiked with the internal standard (DHBA) to a concentration 1 μM . The urine sample was subjected to SPE and the dried eluate was reconstituted in 0.25 mL of water, which represented a 20-fold preconcentration of the analytes. The levels of catecholamines and metanephrines were then calculated using Equation III.1, with the internal standard at 1 μM , and the values of the ionization efficiencies and recoveries for the individual analytes taken from Tables III.2 and III.3, respectively. The calculated concentrations are summarized in Table III.4 and are consistent with values reported for healthy individuals [1,30].

Table III.4. Catecholamine and metanephrine levels in a spot collection of human urine.

Compound	$\mu\text{mol/L}$ of urine
D	1.89
3MT	0.31
NE	0.78
NM	0.51
E	0.07
M	0.20

III.4. CONCLUSIONS

In this chapter, I have described the successful coupling of CE to TOFMS for the simultaneous analysis of catecholamines and metanephrines. This method combines the advantages of high separation efficiency of CE and detection specificity of TOFMS. Coating of the CE capillary with PVA allowed for baseline separation of all analytes and increased the reproducibility of analysis. This also circumvented the need for extensive between-run washing of the capillary with hydroxides, which is necessary to ensure reproducibility with the use of uncoated capillaries.

I have demonstrated the usefulness of this approach by applying this assay to a spot collection of normal human urine from healthy volunteers. The catecholamines and metanephrines were removed from the urine samples simultaneously by SPE on cation-exchange sorbents. The recoveries of all analytes, with the exception of epinephrine, were over 80%. The individual analytes were identified both by location in the electropherogram and by their respective m/z ratios measured by the TOFMS.

Since pressure injection in our case did not yield sufficiently low LOD's, I employed electrophoretic injection. Using a quantitation method based on the calculation of analyte concentration by comparison to an internal standard, I was able to measure catecholamine and metanephrines levels consistent with values reported for healthy individuals.

While the presented assay could be used in clinical practice, improvement of the sensitivity of the MS detection to achieve lower detection limits with pressure injection, which is the preferred mode of injection for quantitation purposes, and thorough validation of this methodology, are still needed. Several different approaches to improving the ionization efficiency of the ESI interface and the efficiency of the ion transmission into the mass spectrometer are outlined in Chapter VI.

III.5. REFERENCES

- [1] P.E. Cryer, in P. Felig, J.D. Baxter, A.E. Broadus, L.A. Frohman (Eds.),
Endocrinology and Metabolism, McGraw Hill, Inc., New York, 1981, Ch.13.
- [2] N.C. Parker, C.B. Levtzow, P.W. Wright, L.L. Woodard, J.F. Chapman, Clin.
Chem. 32 (1986) 1473.
- [3] R.T. Peaston, T.W.J. Lennard, L.C. Lai, J. Clin. Endocrinol. Metab. 81 (1996)
1378.
- [4] M. Hay, P. Mormède, J. Chromatogr. B 703 (1997) 15.
- [5] A. Ciofu, E. Baudin, P. Chanson, A.F. Cailleux, E. Comoy, J.C. Sabourin, M.
Ducreux, G. Schaison, M.Schlumberger, Eur. J. Endocrinol. 140 (1999) 434.

- [6] E. Grouzmann, M. Fathi, M. Gillet, A. de Torrenté, C. Cavadas, H. Brunner, T. Buclin, *Clin.Chem.* 47 (2001) 1075.
- [7] C. Canfell, S.R. Binder, H. Khayam-Bashi, *Clin.Chem.* 28 (1982) 25.
- [8] S. Chen, Q. Li, P.M. Carvey, K. Li, *Rapid Commun. Mass Spectrom.* 13 (1999) 1869.
- [9] E.C.Y. Chan, P.C. Ho, *Rapid Commun. Mass Spectrom.* 14 (2000) 1959.
- [10] M.M. Kushnir, F.M. Urry, E.L. Frank, W.L. Roberts, B. Shushan, *Clin. Chem.* 48 (2002) 323.
- [11] C.P. Ong, S.F. Pang, S.P. Low, H.K. Lee, S.F.Y. Li, *J. Chromatogr.* 559 (1991) 529.
- [12] T. Kaneta, S. Tanaka, H. Yoshida, *J. Chromatogr.* 538 (1991) 385.
- [13] P. Britz-McKibbin, A.R. Kranack, A. Paprica, D.D.Y. Chen, *Analyst* 123 (1998) 1461.
- [14] P. Britz-McKibbin, J. Wong, D.D.Y. Chen, *J. Chromatogr. A* 853 (1999) 535.
- [15] P. Britz-McKibbin, D.D.Y. Chen, *Anal. Chem.* 72 (2000) 1242.
- [16] R. Zhu, W. Th. Kok, *Anal. Chem.* 69 (1997) 4010.
- [17] H. Sirén, U. Karjalainen, *J. Chromatogr. A* 853 (1999) 527.
- [18] K. Vuorensola, H. Sirén, *J. Chromatogr. A* 895 (2000) 317.
- [19] R.D. Smith, C.J. Baringa, H.R. Udseth, *Anal. Chem.* 60 (1988) 1948.
- [20] Y. Takada, M. Yoshida, M. Sakairi, H. Koizumi, *Bunseki Kagaku* 44 (1995) 241.
- [21] E.M. Jäverfalk-Hoyes, U. Bondesson, D.Westerlund, P.E. Andréén, *Electrophoresis* 20 (1999) 1527.

- [22] K. Vuorensola, J. Kokkonen, H. Sirén, R.A. Ketola, *Electrophoresis* 22 (2001) 4347.
- [23] N.J. Clarke, A.J. Tomlison, G. Schomburg, S. Naylor, *Anal. Chem.* 69 (1997) 2786.
- [24] M. Albin, P.D. Grossman, S.E. Moring, *Anal. Chem.* 65 (1993) 489 A.
- [25] G. Hempel, *Electrophoresis* 21 (2000) 691.
- [26] H. Nohta, E. Yamaguchi, Y. Ohkura, H. Watanabe, *J. Chromatogr.* 493 (1989) 15.
- [27] H.-K. Jeon, H. Nohta, Y. Ohkura, *Anal. Biochem.* 200 (1992) 332.
- [28] M. Tsunoda, K. Takezawa, T. Santa, K. Imai, *Anal. Biochem.* 269 (1999) 386.
- [29] K. Takezawa, M. Tsunoda, N. Watanabe, K. Imai, *Anal. Chem.* 72 (2000) 4009.
- [30] W.J. Burke, H.D. Chung, S.W. Li, *Anal. Biochem.* 273 (1999) 111.

CHAPTER IV

DETERMINATION OF SEROTONIN AND ITS PRECURSORS IN HUMAN PLASMA BY CAPILLARY ELECTROPHORESIS/ELECTROSPRAY IONIZATION/TIME-OF-FLIGHT MASS SPECTROMETRY

An approach similar to that described in Chapter III was applied to another family of vasoactive compounds that pose similar challenges for their accurate measurement in human specimens.

IV.1. INTRODUCTION

The bioactive indolamine serotonin (5-hydroxytryptamine, 5HT), is an established neurotransmitter and vasoconstrictor. It is formed by decarboxylation of 5-hydroxytryptophan (5HTP), its immediate precursor, in one of tryptophan's metabolic pathways [1-3]. Serotonin has been implicated in a variety of physiological processes, including smooth muscle contraction, blood pressure regulation, and both peripheral and central nervous system neurotransmission [1-3]. The involvement of 5HT in many pathological conditions, such as depression, schizophrenia, anorexia nervosa, dementia, and carcinoid syndrome has been proven [1-6]. Carcinoid syndrome, characterized by flushing, diarrhea, valvular heart disease, and bronchoconstriction, arises from excessive synthesis and secretion of serotonin (and sometimes 5HTP) by a carcinoid tumor [1-3,7-10].

The most commonly used laboratory test for the detection of a serotonin secreting carcinoid tumor is the measurement of urinary 5-hydroxyindoleacetic acid (5HIAA), a major serotonin metabolite [3,4,7,9,11]. However, in the case of tumors producing only small amounts of serotonin, the predictive value of an increased urinary 5HIAA is low [10]. In addition, the concentration of 5HIAA in urine may be increased by consumption of certain 5HT-rich foods [1,12]. It has been shown that platelet serotonin is the most sensitive indole marker for the diagnosis of carcinoid tumors, especially those with low serotonin production [3,4,7,10].

A variety of methods such as spectrophotometry, fluorometry, enzyme immunoassay, radioimmunoassay, and GC-MS, have been used to measure serotonin [1,13-17]. In clinical practice, however, serotonin is usually assayed by HPLC with either electrochemical [6-8,11,18,19] or fluorometric detection [4,5,9,10,20-22]. Although some of these methods show great sensitivity, they cannot match the identification power and selectivity of a separation technique coupled to mass spectrometric detection [23]. The mass spectrometer gives another dimension to the analysis by identifying the analytes based on their mass-to-charge ratios and, thus, provides the detection specificity that most other types of detectors lack. While a few accounts describing HPLC separation of indolic compounds from various biological matrices followed by mass spectrometric detection have been published [23-25], this methodology has only recently been applied to a clinical determination of serotonin and related indoles in human blood [26].

Several authors have reported the use of CE in the analysis of one or more indolamines in biological matrices including urine, serum, brain tissue, and lysates of

individual cells [27-34]. As with the chromatographic separations, the predominant modes of detection were electrochemical [33,34] and laser-induced fluorescence [28-32].

In this chapter, a method for the analysis of indole markers in human plasma that combines the high separation efficiency of capillary electrophoretic separation and the specificity of time-of-flight mass spectrometry (TOFMS) detection [35,36] is presented. To my knowledge, such an approach has not previously been accomplished for serotonin and related compounds in complex biological specimens such as serum or plasma.

The developed CE-TOFMS method was applied to determination of serotonin and its precursors Trp and 5HTP extracted from platelet-rich plasma using mixed cation exchange solid phase extraction columns. Deuterated serotonin and Trp were used as internal standards in order to increase the reliability of quantitation [17,23]. Plasma specimens from healthy individuals as well as pathological samples were assayed.

IV.2. EXPERIMENTAL

IV.2.1. Materials and chemicals

Serotonin (5-hydroxytryptamine hydrochloride, 5HT), L-tryptophan (Trp), and 5-hydroxy-L-tryptophan (5HTP) were purchased from Sigma (St. Louis, MO, USA). Deuterated internal standards (serotonin- $\alpha,\alpha,\beta,\beta$ -d₄ creatinine sulfate complex, d5HT, and L-tryptophan-2',4',5',6',7'-d₅, dTrp) were purchased from C/D/N Isotopes (Pointe-Claire, Quebec, Canada). HPLC-grade methanol, HPLC-grade water, hydrochloric acid, acetic acid, and formic acid were from Mallinckrodt (Paris, KY, USA). Ammonium hydroxide was from EM Science (A division of EM Industries, Gibbstown, NJ, USA) and ammonium acetate and ammonium formate were from Fisher Scientific (Fair Lawn, NJ,

USA). SPE columns, Oasis MCX 1cc (30 mg), were purchased from Waters (Milford, MA, USA). Centricon[®] centrifugal filter devices with regenerated cellulose 50,000 molecular weight cut-off membranes were from Millipore (Bedford, MA, USA). Fused silica capillaries (75 μm i.d. \times 365 μm o.d. and 50 μm i.d. \times 365 μm o.d., Polymicro Technologies, Phoenix, AZ, USA) were coated with polyvinyl alcohol (PVA, 99+%, average MW 89,000-98,000 g/mol) from Aldrich (Milwaukee, WI, USA) as described in Chapter II.

IV.2.2. Buffers and standard solutions

Ammonium formate separation buffers were prepared at 25 mM concentration and adjusted to a final pH of 3.0 or 3.5 with formic acid. Formic acid solutions (0.5, 1, and 1.5%) were prepared by mixing concentrated formic acid with water in ratios of 0.5:99.5, 1:99, and 1.5:98.5 (v/v), respectively. Ammonium acetate SPE buffer was prepared at 20 mM concentration and adjusted to pH 7.6 with acetic acid. All buffers were filtered using Acrodisc[®] syringe filters with 0.2 μm HT Tuffryn[®] membranes (Pall Gelman Laboratory, Ann Arbor, MI, USA) and degassed by sonication. The concentration of hydrochloric acid SPE wash solution was 0.1 M. SPE eluents were prepared by mixing 30% ammonium hydroxide with 100% methanol in ratios of 5:95, 7.5:92.5, and 10:90 (v/v) to produce 5, 7.5, and 10% solutions, respectively. Stock solutions of 10 mM 5HT, d5HT, Trp, dTrp, and 5HTP were prepared in 0.2% acetic acid and were kept in the dark at $-20\text{ }^{\circ}\text{C}$. Under these conditions, the solutions were stable for at least one month. The stock solutions were thawed and further diluted to the desired concentrations with water immediately prior to use.

IV.2.3. Instrumentation

For the current analytes the following instrumentation was employed: A commercial Crystal CE Model 300 (UNICAM, Madison, WI, USA) capillary electrophoresis apparatus was used for all separations. The separation columns were thermostated to 22 °C. For separations with UV/Vis detection, a Model 759 A UV absorbance detector (Applied Biosystems, Foster City, CA, USA) was used. ChromPerfect 3.54 Data Acquisition software (Justice Laboratory Software, Palo Alto, CA, USA) was used to collect data from the UV detector. A commercial Jaguar™ TOFMS (LECO, St. Joseph, MI, USA) with an in-house built liquid sheath electrospray interface was used as the MS detector. MS data were collected with a sum rate of 3200, which resulted in 1.6 spectra s⁻¹. The nozzle board was heated to 90 °C. All instrumentation used in this work is described in detail in Chapter II.

IV.2.4. Sample collection, preparation, and solid phase extraction

Fresh blood samples for the determination of normal 5HT levels were collected from healthy volunteers into 4-mL Vacutainer® tubes containing 7.2 mg K₂EDTA, and chilled on ice immediately. Within 30 min of collection, the blood was centrifuged at 500 × g for 30 min and the resulting platelet-rich plasma (PRP) was either used immediately or stored frozen at -80 °C. All plasma was analyzed within one week of collection. One- to three-day-old, non-pathological, discarded, EDTA-plasma was obtained at the Brigham Young University Health Center, processed identically to fresh blood samples, and used for SPE optimization and recovery studies.

Discarded pathological blood samples were kindly donated by ARUP Laboratories, SLC, UT. These specimens had been drawn into EDTA Vacutainer[®] tubes, transferred into ARUP Serotonin Transport Tubes (STT) containing ascorbic acid, mixed, frozen immediately, and shipped to ARUP as such. I obtained these samples frozen in the STT's after they had been used for an HPLC whole blood serotonin assay. The frozen samples were thawed and centrifuged in the same way as fresh blood samples. However, because the red blood cells had lysed and released hemoglobin as a consequence of freezing, additional ultrafiltration using Centricon[®] centrifugal filter devices was performed to eliminate hemoglobin and any remaining cell debris before subjecting the samples to SPE.

A modified Waters Generic Oasis MCX method was used for extraction of basic compounds. Oasis MCX columns were conditioned with 1 mL of methanol and 1 mL of 0.5 % (v/v) formic acid, pH 2.5. For recovery studies and analysis of healthy plasma, 1 mL of platelet-rich plasma was mixed with 4 mL of 0.5 % (v/v) formic acid, pH 2.5. For CE-TOFMS, the samples were spiked with deuterated 5HT and Trp (d5HT and dTrp) which served as internal standards. After sample application, the columns were washed with 1 mL of 0.1 M HCl and 1 mL of methanol. The analytes were eluted with 1.3 mL of 7.5% ammonium hydroxide in methanol (v/v) and collected into Eppendorf vials. The eluates were dried using vacuum centrifugation and reconstituted in 100 μ L of water.

The plasma volumes obtained from pathological samples were less than 1 mL. Therefore, these samples were diluted with 0.5 % formic acid to a volume equal to four times the plasma ultrafiltrate volume. The volumes of water used for reconstitution of

the dried sample were also adjusted to provide samples with a concentration factor of four or five. The rest of the procedure was the same as for normal plasma.

IV.2.5. Recovery studies

In order to evaluate extraction recoveries, discarded non-pathological plasma samples were divided into two parts. One portion of the samples was supplemented with analyte standards to final concentrations of 2 μM for 5HT, d-5HT, and 5HTP, and 20 μM for Trp and d-Trp. The second portion (blank) was used without addition of standards. The spiked samples and their corresponding blanks were extracted by SPE and analyzed by CE-UV the same day. The average analyte signal (peak area) from the blank samples was subtracted from the analyte signal from the supplemented samples, and recovery was calculated as the ratio of this difference (between the spiked and blank samples) to the peak areas of a mixture of standards of corresponding concentrations.

IV.2.6. Linearity, detection limits, and quantitation for CE-TOFMS

In order to evaluate linearity and detection limits of the CE-TOFMS method, mixtures of indolamines and their deuterated standards at several different concentration levels were analyzed. The most concentrated mixture consisted of 1.34×10^{-3} M 5HT, 1.01×10^{-3} M d5HT, 1.32×10^{-3} M Trp, 1.08×10^{-3} M dTrp, and 1.02×10^{-3} M 5HTP. This mixture was diluted 10, 20, 100, 200, 1000, 2000, and 10000 times to generate the calibration solutions. The limit of detection (LOD) was calculated from the calibration curve as the concentration corresponding to the value of the y-intercept plus three times

the standard deviation of the y-intercept. The assay linearity was determined as the correlation coefficient, R, values for each individual analyte.

The concentrations of the analytes, C_a , were calculated using the following equation:

$$C_a = C_{dis} \times [A_a / A_{dis}] \times f, \quad (IV.1)$$

where A_a and A_{dis} are the peak areas of the analyte and the deuterated internal standard, respectively, C_{dis} is the concentration of the internal standard, and f is a correction factor that accounts for the fact that signal intensities for the analyte and its internal standard at the same concentration levels are not equal. The factor f is calculated from CE-TOFMS analysis of standard mixtures of analytes and their deuterated standards at known concentrations:

$$f = [A_{ds} / C_{ds}] / [A_{as} / C_{as}], \quad (IV.2)$$

where A_{ds} and A_{as} are deuterated standard and analyte standard peak areas, and C_{ds} and C_{as} are their respective concentrations.

IV.3. RESULTS AND DISCUSSION

IV.3.1. CE separation of indolamines

Although 5HT, Trp, and 5HTP have similar structures, their acid-base characteristics and therefore the dependence of their electromigration as a function of pH are somewhat different. Trp and 5HTP are amino acids and therefore they contain two ionizable moieties: a carboxylic acid group (pK_a 2.4 and 2.7, respectively) and an amine

functionality (pK_a 9.4 and 9.6, respectively). 5HT is an amine with an amino group pK_a of 9.8. From the comparison of the pK_a 's of these compounds, it is clear that while 5HT is positively charged over a wide range of pH, Trp and 5HTP carry a net positive charge only below pH \sim 3-3.5. 5HT and 5HTP also contain an ionizable hydroxyl group on the indole ring, but their pK_a 's (11.1 and 10.7, respectively) are such that these groups do not contribute to the net charge of the analytes under most working conditions, and therefore are not considered here.

Most published methods for the separation of all or some of the indolamines use high pH, nonvolatile buffers, uncoated capillaries [28-30,32-34] and often micelle-forming additives [28-30]. While such approaches seemed to work well with UV, laser-induced fluorescence, or electrochemical detectors, nevertheless, they are not suitable for ESI-MS detection. Although some studies have demonstrated that nonvolatile buffers and/or buffer additives can, under some circumstances, be used with liquid sheath ESI-MS [38-40], it is generally accepted that volatile buffers free of non-volatile additives provide the best ESI-MS sensitivity and overall performance [40-42].

I chose to work in the lower range of pH where there is a wider selection of volatile buffers. Using an uncoated silica capillary, I evaluated 0.5% formic acid, pH 2.5, and 25 mM ammonium formate, pH 3.0 and 3.5, for the separation of 5HT, Trp, and 5HTP. While 5HT was well separated from the other two analytes, it was not possible to separate Trp from 5HTP under these conditions. At higher pH, Trp and 5HTP had a net zero charge and thus migrated with the electroosmotic flow (EOF) marker.

When a PVA coated capillary was used in combination with formic acid as a buffer, I obtained baseline separation of 5HT, Trp, and 5HTP. Increasing the

concentration of formic acid from 0.5 to 1.5 %, and thus decreasing the buffer pH, reduced the migration times and also produced sharper peaks for Trp and 5HTP. Figure IV.1 shows a CE-UV separation of a standard mixture of 5HT and its precursors in 1.5 % formic acid, pH 2.07. The PVA coating was stable under these conditions for several weeks.

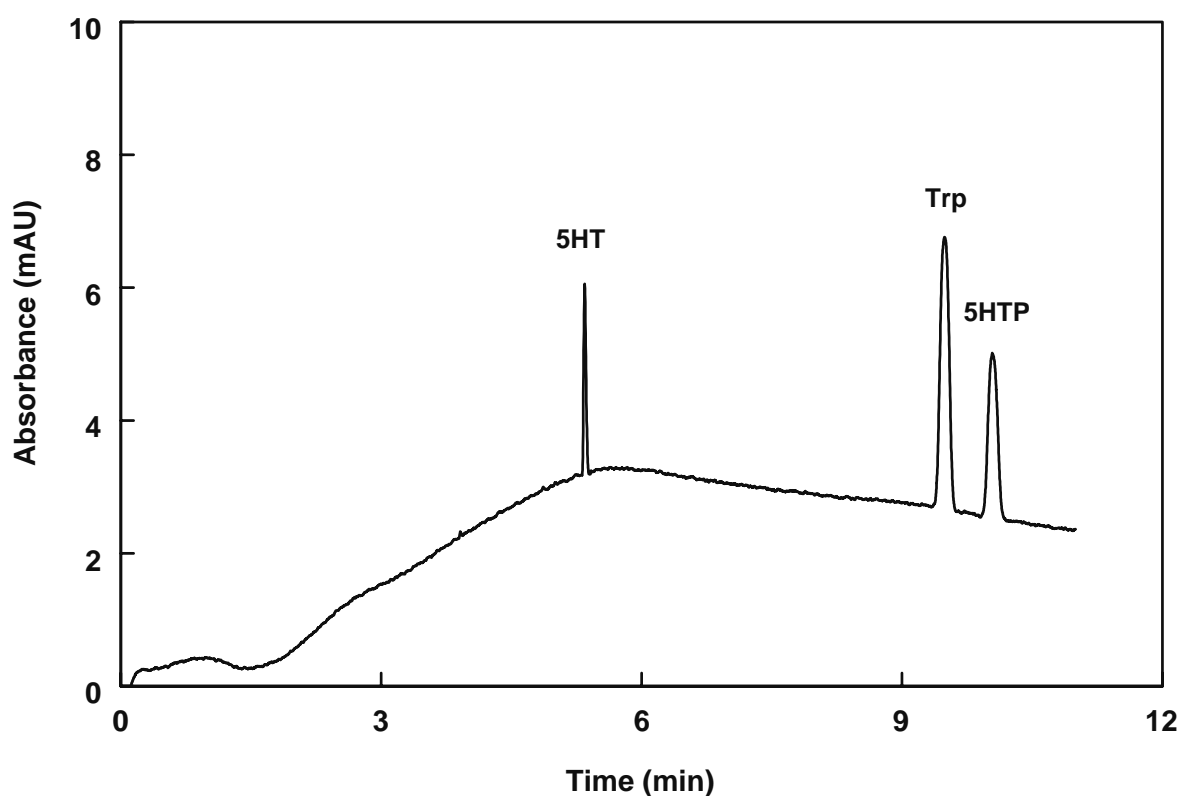

Figure IV.1. CE-UV separation of indolamine standards. Sample: 6.70 μM 5HT, 26.4 μM Trp, and 20.4 μM 5HTP. Conditions: buffer, 1.5% formic acid (pH 2.07); capillary, (52+11) cm, 50 μm i.d., 360 μm o.d., PVA coated; injection, 100 mBar/0.2 min; run voltage, 30 kV; current, 40 μA ; $\lambda=215$ nm.

IV.3.2. CE-TOFMS analysis of standard compounds

A liquid sheath ESI interface was used in this work. Several mixtures of methanol/water and acetonitrile/water containing 0.2% formic acid were tested for their suitability as liquid sheath solutions for CE-TOFMS of serotonin and its precursors. Standards of the analytes were diluted in 60:40 and 80:20 acetonitrile/water, and 50:50, 60:40 and 80:20 methanol/water mixtures, all containing 0.2% formic acid. Formic acid was chosen as the liquid sheath electrolyte in order to eliminate or at least reduce the formation of moving ionic boundaries, a phenomenon that occurs when background electrolyte contains different counterions than the liquid sheath [43]. The mixtures were analyzed by direct infusion using a commercial ESI interface. The compounds exhibited a much higher signal in solutions containing methanol than in acetonitrile mixtures, consistent with the observations reported by Artigas and Gelpí [23]. A mixture of methanol and water, 60:40, gave the highest signal.

Nevertheless, when methanol/water solutions containing 40% or 50% water were used as liquid sheaths for CE-MS separation, it was difficult to maintain a well shaped, stable Taylor cone. Therefore, the methanol content was increased to 70%. Using this less viscous solution, the electrospray was more stable, while still facilitating very good analyte signal.

Another parameter that played a role in signal sensitivity was the concentration of the separation buffer [44,45]. I have found that decreasing the concentration of formic acid in the CE electrolyte from 1.5 to 0.5% increased the signal intensity of the analytes. It is well known that the buffer electrolytes compete for charges with the analytes, thus decreasing the detection sensitivity [45]. To compensate for the longer separation times

resulting from the higher pH and lower ionic strength of the buffer and to suppress occasional formation of bubbles in the capillary, a small positive pressure (10 mBar) was applied to the injection end of the separation capillary during the CE run. This pressure did not have a significant influence on the peak shape and separation efficiency, however, it greatly enhanced the electrospray stability and overall performance of the analysis.

The mass spectrometer voltage settings and nitrogen counter flow were initially adjusted for highest analyte signal while directly infusing standards of indolamines in methanol/water/formic acid liquid sheath solutions using the commercial interface. However, the voltage necessary for the formation of a stable electrospray was about 1000 V higher for the CE-TOFMS liquid sheath interface than the voltage used with the microspray continuous infusion commercial interface. Such a large voltage change can be expected to influence the rest of the MS voltages on the instrument's front end. Therefore, the voltages and curtain gas flow were adjusted to optimize signal while spraying approximately 100- μ M mixture of indolamines directly through the CE separation capillary using the CE-TOFMS liquid sheath interface.

The commercial ESI interface was also used for the determination of the types of ions produced while electrospraying the analytes. The analytes were diluted in methanolic sheath liquid and the resulting ions were determined from summed mass spectra. Two types of ions were observed: less intense (M+1) molecular ions and more intense product ions that resulted from a 17-Da fragment leaving the main (M+1) structure. Judging by the mass of the 17-Da fragment, it could correspond to either an OH group or a NH₃ group. Both are a possibility for 5HT, d5HT and 5HTP, because these compounds contain a hydroxyl group attached to the indole ring. However, Trp and

dTrp do not have a hydroxyl, yet they still form product ions with mass-to-charge (m/z) ratio of 17 Da less than the molecular ions. This suggests that the NH_3 group is cleaved off the molecular ion. Our hypothesis is supported by the work of McClean et al., Danaceau et al., and Numan and Danielson [25,26,46].

When standards of the analytes were subjected to CE-TOFMS analysis, I found that there were additional product ions present, apparently resulting from further fragmentation of the molecules [25,26,46]. The molecular and product ions of the analytes are listed in Table IV.1 along with their relative abundances. The relative ion abundances were calculated using the CE-TOFMS peak areas and normalized to the signal of the most intense product ions (loss of a 17-Da fragment). These major product ions were assigned relative abundances of 100%. I have found one inconsistency in the ionization pattern: dTrp was expected to have its major ionization product at m/z 193, which would be consistent with the loss of an NH_3 group. Instead, I found that the most intense ion had m/z 192. One possible explanation of this phenomenon is an exchange of one of the deuterium atoms for hydrogen, which would account for the difference in m/z .

Comparing the relative abundances of the 5HT and d5HT ions with those of Trp, dTrp, and 5HTP ions, it can be seen that while 5HT and d5HT ionize almost exclusively as the $(M+1-17)$ ions, the ionization pattern for Trp, dTrp, and 5HTP involves quite intense molecular ions and other fragments. This observation, along with CE peak broadening for later eluting Trp, dTrp and 5HTP, may explain why the signal of Trp, dTrp, and 5HTP appeared less intense than the signal of 5HT and d5HT using TOFMS detection.

Table IV.1. Mass-to-charge (m/z) ratios and relative abundances (RA) of protonated molecular ions and fragment ions of the analytes.

Ions	5HT		d5HT		Trp		dTrp		5HTP	
	m/z	RA	m/z	RA	m/z	RA	m/z	RA	m/z	RA
(M+1) ions	177	4.3%	181	6.3%	205	31.2%	210	37.9%	221	28.7%
Major products	160	100%	164	100%	188	100%	192	100%	204	100%
Minor products	132	1.3%	136	1.3%	160	3.2%	193	65.2%	162	17.7%
					146	35.1%	164	8.3%	160	4.4%
					132	7.4%	150	26.2%		
							136	8.6%		

Having optimized the separation and detection parameters, I determined the detection limits (LOD) and assay linearity using standard solutions of indolamines as described in the Experimental section. The values of LOD's for the individual analytes and internal standards together with correlation coefficients and regression equations are summarized in Table IV.2.

Table IV.2. Correlation coefficients (R), regression equations, and detection limits for CE-TOFMS of indolamine standards.

Compound	Regression Equation	R	LOD (μ M)
5HT	$y = 4.03E+07x + 0.89$	0.9998	0.15
d5HT	$y = 2.56E+07x + 1.13$	0.9998	0.13
Trp	$y = 1.13E+07x + 4.96$	0.9998	0.66
dTrp	$y = 7.87E+06x + 1.76$	0.9995	0.52
5HTP	$y = 5.25E+06x + 3.07$	0.9994	3.23

Figure IV.2 shows the separation of a standard mixture of indolamines and their deuterated internal standards under optimized CE-TOFMS conditions. The analyte signal is presented as the m/z traces of the most intense ions.

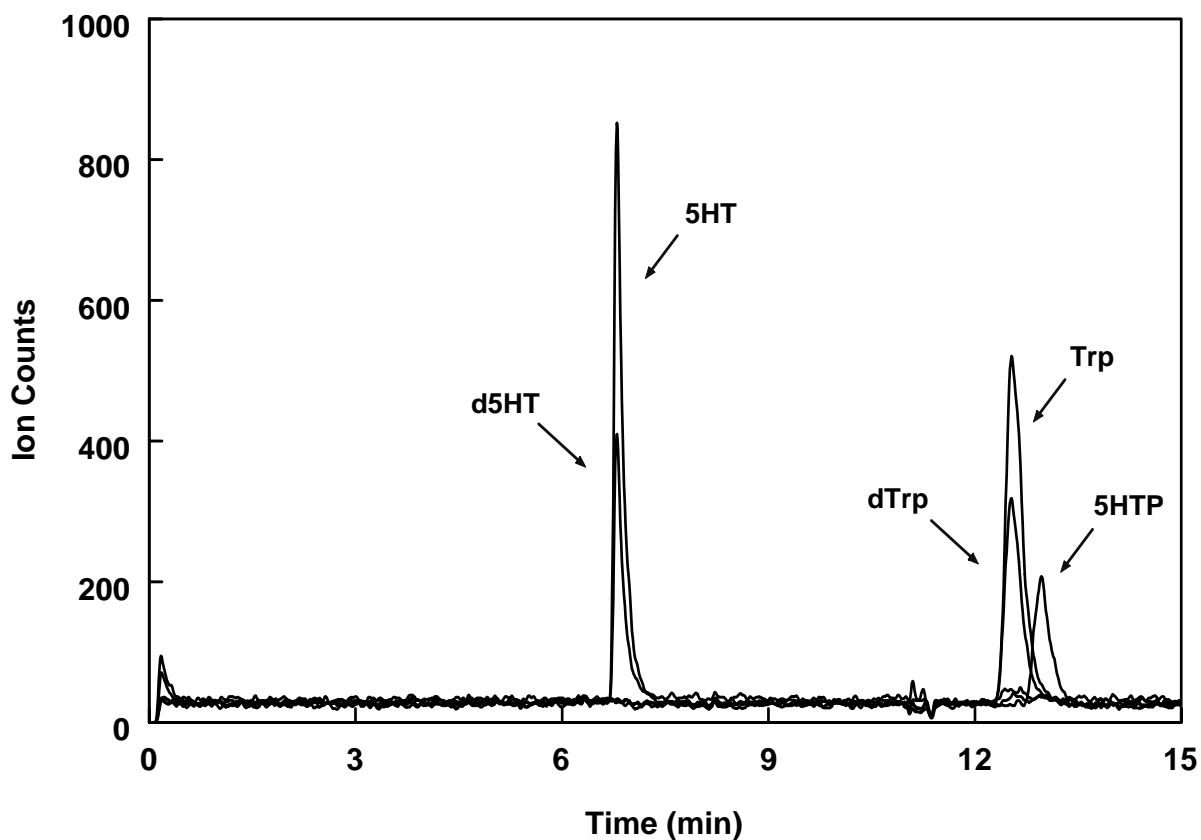

Figure IV.2. CE-TOFMS analysis of indolamine standards. Sample: 6.70 μM 5HT, 5.05 μM d5HT, 26.4 μM Trp, 21.6 μM dTrp, and 20.4 μM 5HTP. CE conditions: buffer, 0.5% formic acid (pH 2.5); capillary, 60 cm length, 50 μm i.d., 360 μm o.d., PVA coated; injection, 80 mBar/0.2 min; run voltage/pressure, 30 kV/10 mBar; current, 19 μA . MS conditions: ESI voltage, 3400 V; curtain gas flow, 600 mL/min; liquid sheath flow and composition, 2 $\mu\text{L}/\text{min}$, 70:30:0.2 methanol/water/formic acid, (v/v).

IV.3.3. Sample cleanup

Because both CE separation and electrospray ionization-TOFMS detection are very sensitive to the presence of high concentrations of salts, sample pretreatment was primarily to minimize the salt content. In addition, the developed sample workup allowed for a 4 to 10-fold concentration of the specimens.

The SPE procedure described by Kwarts et al. [5], utilizing the weak cation exchanger Amberlite CG-50, for the use on Supelclean LC-WCX (100 mg, 1 mL) columns was tested. Briefly, the columns were conditioned with 2 mL of methanol, 1 mL of water and 2 mL of ammonium acetate (20 mM, pH 7.6). Analyte standards in PBS (pH 7.46) were mixed 1:1 (v/v) with ammonium acetate (20 mM, pH 7.6), and 1 mL aliquots were applied on the columns. Following a wash with 1 mL of ammonium acetate (20 mM, pH 7.6) and 1.5 mL of 0.01 M acetic acid, the analytes were eluted with 1.5 mL of 1 M acetic acid containing 4% (by weight) ascorbic acid. However, in my hands, the analysis of the eluates yielded very low recoveries and the analytes were also present in small amounts in the acetic acid wash. When the eluates were dried in a vacuum centrifuge in order to obtain more concentrated samples, substantial white solid residue (most likely ascorbic acid), insoluble in the volumes of water intended for sample reconstitution, remained. As expected, it was also observed that the high concentrations of charged species (acetic and ascorbic acids) in the eluent had a detrimental effect on the analyte peak shapes. I have, therefore, concluded that this procedure was not suitable for use with CE separation.

In Chapter III, I successfully utilized Oasis MXC cation exchange columns for the solid phase extraction of catecholamines and metanephrines [35]. Since indolamines

have structures similar to the above-mentioned compounds, I tested the Oasis MXC mixed mode cation exchange columns for SPE of indolamines. Several SPE parameters were investigated: sample matrix, wash solvent, elution solvent concentration and volume, and the addition of a neutralizing agent. The manufacturer's extraction method suggested loading an acidified sample, washing the cartridge with 0.1 M HCl and methanol and eluting the analytes with 5% ammonium hydroxide in methanol.

Preliminary experiments were performed with indolamine standards in various matrices, namely ammonium acetate (20 mM, pH 7.6), PBS (pH 7.46), water, or formic acid (0.1%, 0.5%, and 1.5%). Ammonium acetate and PBS yielded marginal recoveries of 5HT (~60%) when either 0.1 M HCl wash or water wash was used. Recoveries of Trp and 5HTP were very low (a few percent) with a water wash, but increased dramatically for Trp (above 90%) and marginally for 5HTP (~40-50%) with HCl wash. The results were similar for plasma samples diluted with ammonium acetate.

In other experiments, analyte standards diluted in 0.5% formic acid or water gave recoveries of 70% or higher for 5HT and in the high 80 to high 90% range for Trp and 5HTP. The recoveries obtained from 0.1% and 1.5% formic acid were slightly lower than those from 0.5% formic acid. However, when these matrices were used to dilute spiked plasma samples, good overall recoveries were obtained only from 0.5% formic acid in combination with an HCl wash. The recoveries of 5HT were influenced the least by the matrix and wash, whereas Trp and 5HTP yielded zero to very low recoveries when water dilution of plasma and/or a water wash were used. Therefore, the dilution of plasma with 0.5% formic acid (1:4) and an HCl wash were used in all subsequent experiments.

The analytes captured on the SPE MCX sorbent were eluted with a mixture of 30% ammonium hydroxide and 100% methanol. Two and a half, 5.0, 7.5, and 10.0% (v/v) solutions of ammonium hydroxide in methanol were tested. The recoveries were very low using 2.5% ammonium hydroxide, but increased markedly when 5.0% and 7.5% ammonium hydroxide eluents were used (with slightly higher recoveries at 7.5%) and decreased again with 10% ammonium hydroxide in methanol. Therefore, 7.5% ammonium hydroxide in methanol was chosen for the elution of serotonin and its precursors from the SPE columns.

The volume of solvent necessary to elute the analytes was also determined. The eluent was applied to columns in four 0.5-mL portions and each fraction was collected, dried and analyzed separately. It was found that serotonin eluted in the first two fractions with approximately equal recoveries of ~35% in each, with the third fraction containing another ~3-6%. Trp and 5HT eluted almost quantitatively in the first fraction, with zero to a few percent eluting in the second fraction. It was therefore decided that eluent volumes of 1.3 mL were sufficient for quantitative recovery of all three compounds. Because 1.5-mL Eppendorf vials were used for the eluate collection and drying, using 1.3 mL rather than 1.5 mL also decreased the risk of spills during sample handling. Water and 0.5% formic acid were tested as column conditioning solvents. When the columns were conditioned with formic acid, slightly better recoveries were obtained.

For the SPE of catecholamines and metanephrines [35], I used a small amount of concentrated acetic acid to neutralize the ammonium hydroxide, and thus limit the exposure of the analytes to high pH. Since indolamines are also sensitive to pH extremes, I used this same precaution in their SPE analysis. However, after the

neutralization, an unknown peak was found migrating immediately following the serotonin peak. In order to investigate the origin of that peak, 1.3 mL of the ammonium hydroxide eluent was placed in an Eppendorf vial, spiked with the analyte standards, and small amounts of acetic acid (20 and 90 μ L) or formic acid (60 μ L) were placed on the bottoms of some the vials. These solutions were then dried in a vacuum centrifuge. Upon CE analysis it was found that the extra peak was a degradation product of 5HT. The signal of the 5HT degradation product was at most 4% of the serotonin signal for samples with formic acid or samples with no acid added, while samples containing acetic acid exhibited degradation product peaks from ~10-50% of the 5HT signal. The samples with no acid added had the highest recoveries of all analytes and dried in just 1.5-2.0 h, while the samples with added acid took several hours for complete drying, formic acid samples being the slowest to dry. Since ammonium hydroxide is quite volatile, it was probably removed very quickly from the samples containing no acid additive and thus the exposure of the analytes to high pH was limited anyway.

In summary, based on the above results, it was determined that the following SPE conditions provided the best recoveries for 5HT, Trp and 5HTP: column conditioning with 1 mL of methanol and 1 mL of 0.5% formic acid, application of plasma sample acidified with 0.5% formic acid 1:4 (v/v), washing with 1 mL of 0.1 M HCl, elution with 1.3 mL of 7.5% ammonium acetate, and drying in a vacuum centrifuge ~1.5-2 h. The dried eluates were reconstituted in 100 μ L of water, except when the ultrafiltrates of the pathologic samples were analyzed. In the latter case, the reconstitution volumes were adjusted to yield a four-fold concentration of the analytes.

As described in the Experimental Section, the SPE recoveries of indolamines were determined using non-pathological plasma samples enriched with the analyte standards at concentrations 2 μM for 5HT, d5HT, and 5HTP and 20 μM for Trp and dTrp. As predicted, I found good agreement between the recoveries of 5HT and d5HT, as well as between Trp and dTrp. The SPE recoveries are summarized in Table IV.3.

Table IV.3. SPE recoveries of indolamines from plasma samples spiked with 2 μM 5HT, d5HT and 5HTP, and 20 μM Trp and dTrp. Recoveries are given as the mean \pm SD for six sets of experiments

Compound	Recovery (%)
5HT	74.8 \pm 2.7
d5HT	69.6 \pm 1.7
Trp	90.4 \pm 2.3
dTrp	88.0 \pm 2.7
5HTP	98.7 \pm 5.3

IV.3.4. Determination of serotonin and its precursors in SPE extracts of human platelet-rich plasma

Following optimization of the SPE conditions, I analyzed extracts of both healthy and pathological human plasma using CE-UV as well as CE coupled to TOFMS. Figures IV.3 and IV.4 show representative examples of CE-UV separation of SPE extracts of plasma with normal indole marker levels and pathological plasma, respectively. CE-TOFMS analysis of the same samples is presented in Figures IV.5 and IV.6.

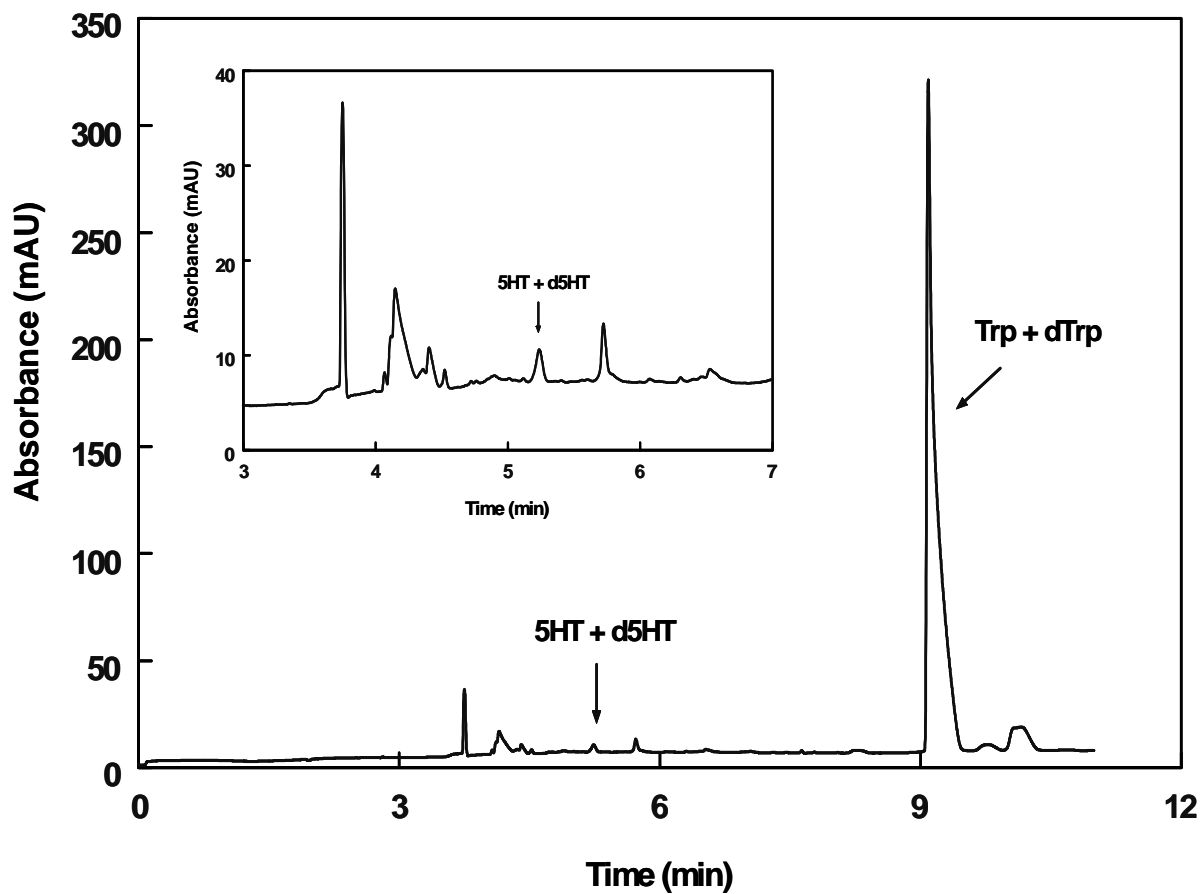

Figure IV.3. CE-UV analysis of an SPE extract of 1 mL of healthy human plasma spiked with deuterated standards (2.02 μM d5HT, 108.0 μM dTrp). The extract was reconstituted in 100 μL of water. Conditions as in Figure IV.1.

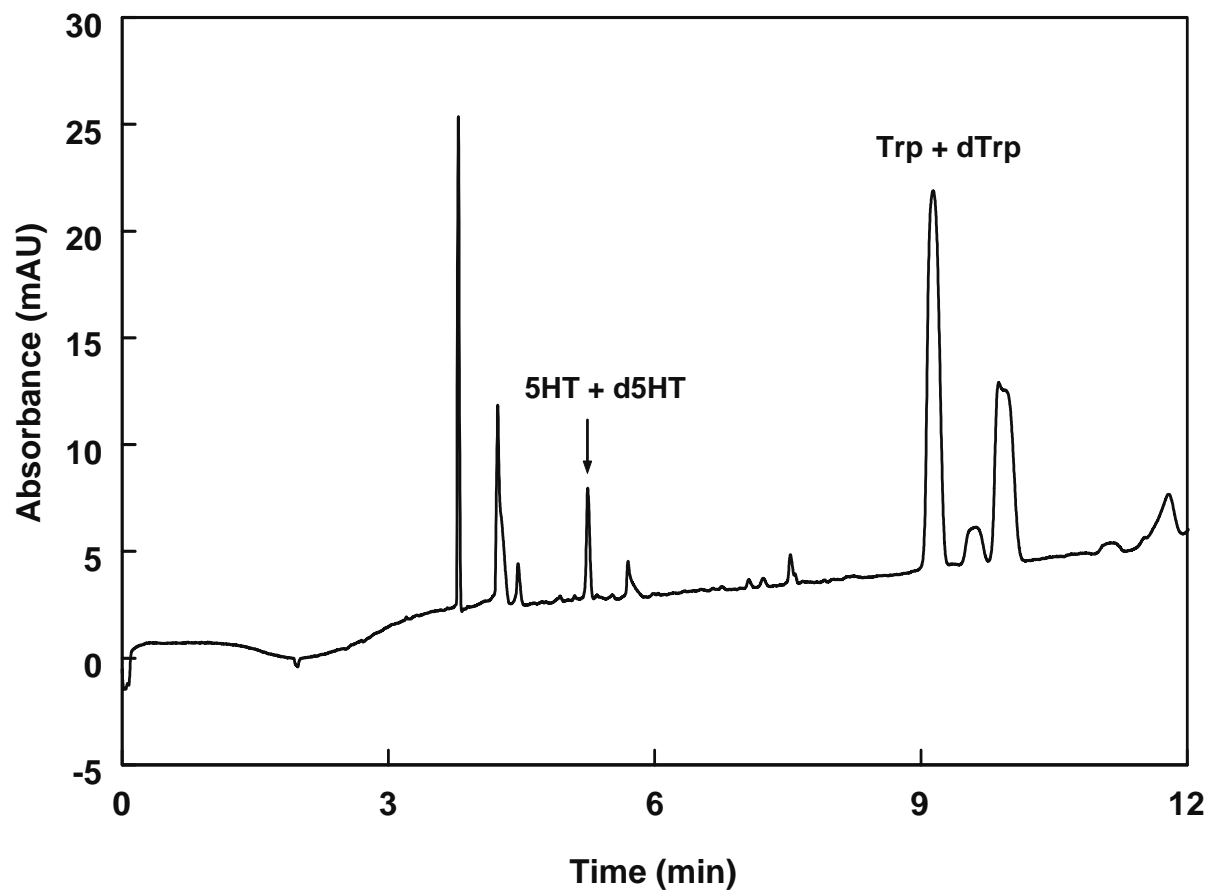

Figure IV.4. CE-UV analysis of an SPE extract of 150 μL of pathological plasma spiked with deuterated standards (4.04 μM d5HT, 21.6 μM dTrp). The extract was reconstituted in 60 μL of water. Conditions as in Figure IV.1.

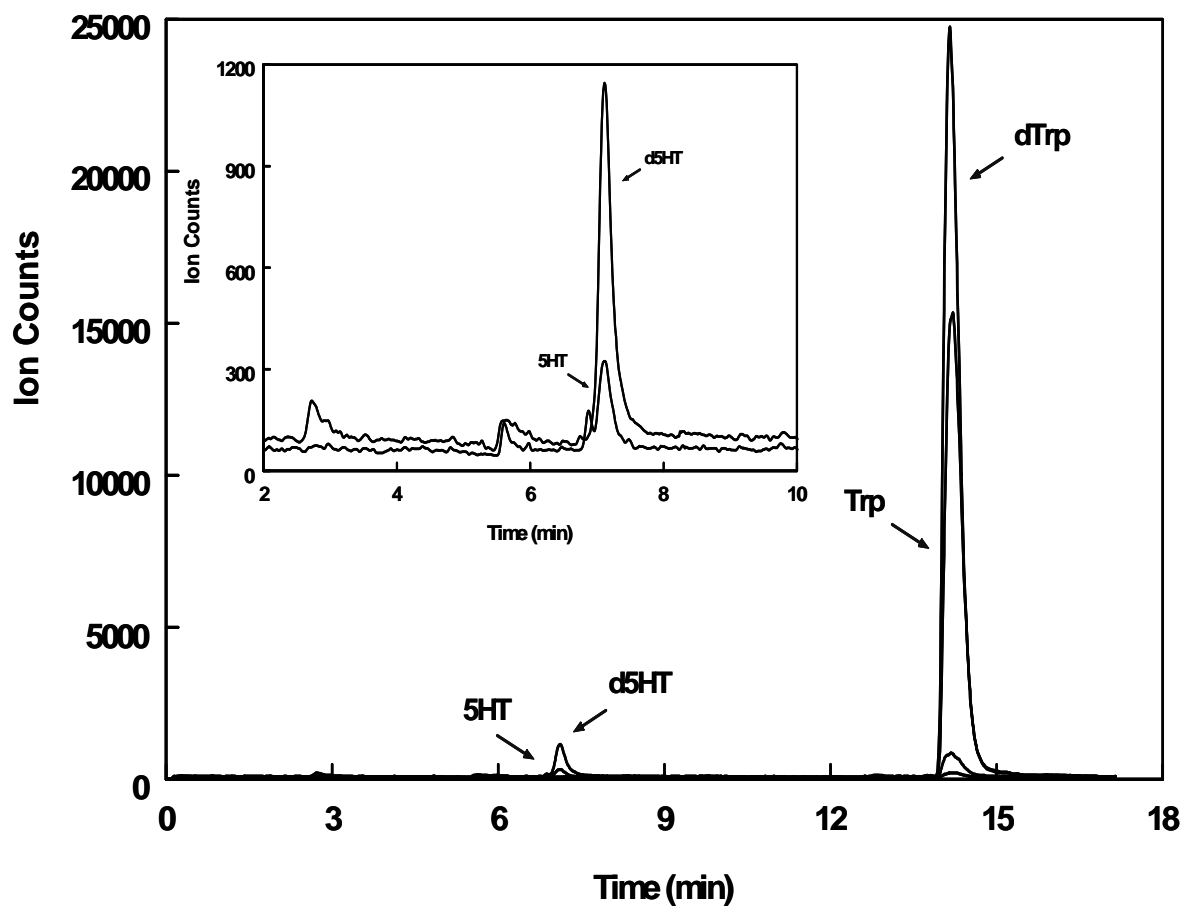

Figure IV.5. CE-TOFMS analysis of an SPE extract of 1 mL of healthy human plasma spiked with deuterated standards reconstituted in 100 μ L of water (same sample as in Figure IV.3). CE and MS conditions same as in Figure IV.2, except CE injection was 100 mBar/0.2 min and ESI voltage was 3550 V.

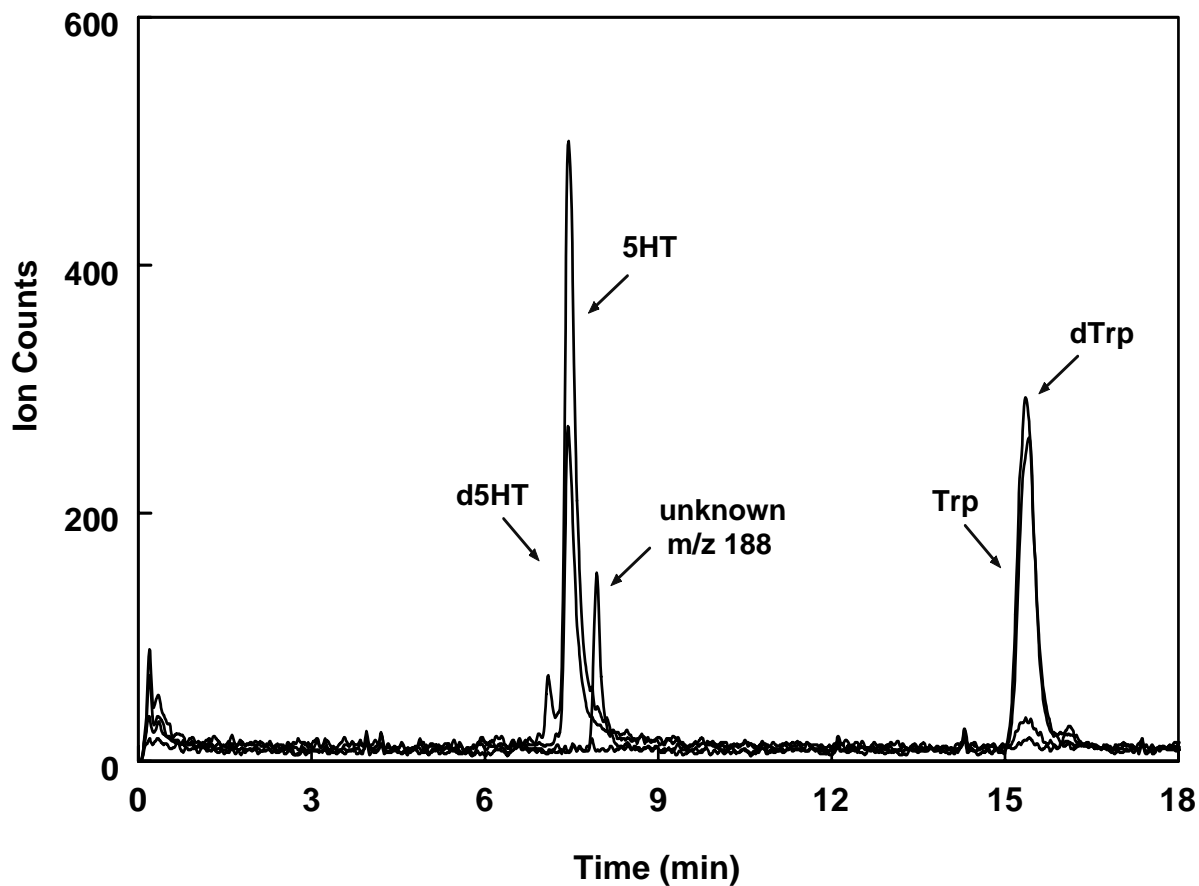

Figure IV.6. CE-TOFMS analysis of an SPE extract of 150 μL of pathological plasma spiked with deuterated standards (4.04 μM d5HT, 21.6 μM dTrp) and reconstituted in 60 μL of water (same sample as in Figure IV.4). CE and MS conditions same as in Figure IV.2, except ESI voltage was 3380 V.

In CE with non-selective UV detection, the position of the peak on the electropherogram is the only determining factor for the compounds of interest. If two compounds coelute, the UV detector cannot distinguish between them. On the other hand, as can be seen from Figures IV.5 and IV.6, using TOFMS, the analytes are identified on the basis of both their position in the electropherogram and their characteristic m/z ratios. Although the TOFMS detector collects, with each pulsed extraction, a complete spectrum of the sample that is being electrosprayed, the instrument software allows for the construction of a selected ion plot, which shows only the desired m/z traces. This simplifies the CE-TOFMS electropherograms compared to the ones produced by CE-UV, as can be seen by comparing Figures IV.5 and IV.6 with Figures IV.3 and IV.4.

To aid analyte quantitation, I used deuterated isotopes of serotonin and tryptophan [17,23]. Deuterated isotopes are ideal as internal standards, because their chemical properties are nearly identical to those of corresponding non-deuterated compounds. The data contained in Figures IV.5 and IV.6 and Tables IV.1 and IV.3 show that the deuterated isotopes mimic the electrophoretic migration, MS fragmentation, and SPE behavior of the analytes very closely. In order to evaluate the linearity and comparability of the analyte and deuterated standard signals as a function of analyte concentration in real samples, I have analyzed several aliquots of low-serotonin plasma, each spiked with d5HT internal standard (2 μM). The aliquots were enriched with varying concentrations of 5HT (0, 0.268, 1.34, 6.70, and 13.40 μM) as the primary compound of interest, extracted by SPE and analyzed on CE-TOFMS. The ratio of 5HT to d5HT signals was plotted against the concentration of 5HT added to the sample aliquots. The relationship

was found to be linear in the given concentration range, with a regression equation $y = 0.7353x + 0.1734$ and a correlation coefficient $R = 0.9994$.

Because of the high degree of linearity of the internal standard calibration response, it is reasonable to assume that one point calibration gives sufficient quantitative accuracy. Therefore, the concentrations of 5HT and Trp in plasma samples were calculated using Equations IV.1 and IV.2 as described in the Experimental Section. With the one point calibration, it was necessary to use a factor correcting for the fact that the analyte and its deuterated standard at equal concentrations did not give the same signal intensities, however the relationship between the concentration ratios and the intensity ratios was consistent. The correction factor was calculated based on data obtained from CE-TOFMS analysis of a mixture of standards of both deuterated and non-deuterated compounds. Using this approach, it was sufficient to analyze only one standard mixture in connection with assaying several biological samples instead of running a set of calibration standards and constructing a calibration curve. Because no deuterated isotope of 5HTP was easily available, the quantitation of 5HTP in samples with increased concentrations of this compound could be estimated using deuterated tryptophan, which migrated very close to 5HTP.

The concentrations determined for the healthy plasma sample shown in Figure IV.5 were $0.35 \mu\text{M}$ for 5HT and $56.39 \mu\text{M}$ for Trp, which is consistent with the levels of these compounds reported for normal specimens [4,26]. The pathological samples showed increased levels of 5HT and a decrease in the concentration of Trp, which is also consistent with the data obtained by Kema et al. [3,4]. The concentrations of 5HT and Trp in the pathological sample shown in Figure IV.6 were determined to be $5.25 \mu\text{M}$ and

13.32 μM , respectively. 5HTP was not detected in healthy or pathological human plasma, which is in agreement with observations published by Kema et al. [3,4].

IV.4. CONCLUSIONS

In this chapter, I have presented the use of highly specific and selective MS detection coupled to a capillary electrophoretic separation for the determination of serotonin and its precursors tryptophan and 5-hydroxytryptophan in complex biological matrices such as human plasma. The analytes were successfully removed from the plasma samples and preconcentrated by solid phase extraction. The recoveries were 74.8 ± 2.7 for 5HT, 90.4 ± 2.3 for Trp and 98.7 ± 5.3 for 5HTP. Deuterated isotopes of 5HT and Trp were added as internal standards to the specimens to aid in the quantitation of the analytes. All analytes and their internal standards extracted from plasma were well resolved from other peaks by CE and could be determined both by location in the electropherogram (confirmed by the co-migration of its deuterated isotope) and by their characteristic m/z ratio. Submicromolar detection limits were achieved for standard mixtures of all compounds and their deuterated isotopes with the exception of 5HTP where the detection limits were in the low micromolar range. Due to the concentration effect of SPE, the technique is capable of determining plasma concentration of the compounds of interest that are below the limits of detection for standard mixtures. While 5HTP was not present in any of the analyzed samples, I was able to determine the concentrations of 5HT and Trp quantitatively in both normal healthy and pathological plasma.

IV.5. REFERENCES

- [1] R.J. Whitley, A.W. Meikle, N.B. Watts, in C.A. Burtis, E.R. Ashwood (Eds.), Tietz Textbook of Clinical Chemistry, W.B. Saunders Comp., Philadelphia, 1994, Ch.35.
- [2] P.M.M. Van Haard, S. Pavel, J. Chromatogr. 429 (1988) 59.
- [3] I.P. Kema, E.G.E. de Vries, F.A.J. Muskiet, J. Chromatogr. B 747 (2000) 33.
- [4] I.P. Kema, W.G. Meijer, G. Meiborg, B. Ooms, P.H.B. Willemse, E.G.E. de Vries, Clin. Chem. 47 (2001) 1811.
- [5] E. Kwarts, J. Kwarts, H. Rutgers, Ann. Clin. Biochem. 21 (1984) 425.
- [6] P.C. Tagari, D.J. Boullin, C.L. Davies, Clin. Chem. 30 (1984) 131.
- [7] I.P. Kema, E.G.E. de Vries, A.M.J. Schellings, P.E. Postmus, F.A.J. Muskiet, Clin. Chem. 38 (1992) 534.
- [8] I.P. Kema, E.G.E. de Vries, M.J.H. Slooff, B. Biesma, F.A.J. Muskiet, Clin. Chem. 40 (1994) 86.
- [9] E. Pussard, N. Guigueno, O. Adam, J.-F. Guidicelli, Clin. Chem. 42 (1996) 1086.
- [10] W.G. Meijer, I.P. Kema, M. Volmer, P.H.B. Willemse, E.G.E. de Vries, Clin. Chem. 46 (2000) 1588.
- [11] M.-S. Lee, F.-C. Cheng, H.-Z. Yeh, T.-Y. Liou, J.-H. Liu, Clin. Chem. 46 (2000) 422.
- [12] I.P. Kema, A.M.J. Schellings, G. Meiborg, C.J.M. Hoppenbrouwers, F.A.J. Muskiet, Clin. Chem. 38 (1992) 1730.
- [13] J. Chauveau, V. Fert, A.M. Morel, M.A. Delagee, Clin. Chem. 37 (1991) 1178.
- [14] F. Engbaek, B.Voldby, Clin. Chem. 28 (1982) 624.

- [15] I. Hammel, Y. Naot, E. Ben-David, *Anal. Biochem.* 90 (1978) 840.
- [16] S. Baba, M. Utoh, M. Horie, Y. Mori, *J. Chromatogr.* 307 (1984) 1.
- [17] T. Hayashi, M. Shimamura, F. Matsuda, Y. Minatogawa, H. Naruse, *J. Chromatogr.* 383 (1986) 259.
- [18] B. Takkenberg, E. Endert, H.E. Van Ingen, M. Ackermans, *J. Chromatogr.* 565 (1991) 430.
- [19] C.M. Middelkoop, G.A. Dekker, A.A. Kraayenbrink, C. Popp-Snijders, *Clin. Chem.* 39 (1993) 1675.
- [20] G.M. Anderson, F.C. Feibel, D.J. Cohen, *Life Sciences* 40 (1987) 1063.
- [21] J. De Jong, U.R. Tjaden, E. Visser, W.G. Meijer, *J. Chromatogr.* 419 (1987) 85.
- [22] T.J. Panholzer, J. Beyer, K. Lichtwald, *Clin. Chem.* 45 (1999) 262.
- [23] F. Artigas, E. Gelpí, *J. Chromatogr.* 394 (1987) 123.
- [24] A. Slominski, I. Semak, A. Pisarchik, T. Sweatman, A. Szczesniowski, J. Wortsman, *FEBS Letters* 511 (2002) 102.
- [25] S. McClean, R.C. Robinson, C. Shaw, W.F. Smyth, *Rapid Commun. Mass Spectrom.* 16 (2002) 346.
- [26] J.P. Danaceau, G.M. Anderson, W.M. McMahon, D.J. Crouch, *J. Anal. Toxicology* 27 (2003) 440.
- [27] A. García, M. Heinänen, L.M. Jiménez, C. Barbas, *J. Chromatogr. A* 871 (2000) 341.
- [28] K.C. Chan, G.M. Muschik, H.J. Isaaq, *J. Chromatogr. A* 718 (1995) 203.
- [29] D.M. Paquette, R. Sing, P.R. Banks, K.C. Waldron, *J. Chromatogr. B* 714 (1998) 47.

- [30] Z. Chen, J. Wu, G.B. Baker, M. Parent, N.J. Dovichi, *J. Chromatogr. A* 914 (2001) 293.
- [31] A.M. Ho, E.S. Yeung, *J. Chromatogr. A* 817 (1998) 377.
- [32] X. Zhang, J.V. Sweedler, *Anal. Chem.* 73 (2001) 5620.
- [33] G. Chen, J.N. Ye, J.S. Cheng, *Chromatographia* 52 (2000) 137.
- [34] G. Chen, J. Cheng, J. Ye, *Fresenius J. Anal. Chem.* 370 (2001) 930.
- [35] Z.D. Peterson, D.C. Collins, C.R. Bowerbank, M.L. Lee, S.W. Graves, *J. Chromatogr. B* 776 (2002) 221.
- [36] Z.D. Peterson, C.R. Bowerbank, D.C. Collins, M.L. Lee, S.W. Graves, *J. Chromatogr. A* 992 (2003) 169.
- [37] N.J. Clarke, A.J. Tomlison, G. Schomburg, S. Naylor, *Anal. Chem.* 69 (1997) 2786.
- [38] R.D. Smith, J.A. Loo, C.J. Baringa, H.R. Udseth, C.G. Edmonds, *J. Chromatogr.* 480 (1989) 211.
- [39] W. Nashabeh, K.F. Greve, D. Kirby, F. Foret, B.L. Karger, D.H. Reifsnnyder, S.E. Builder, *Anal. Chem.* 66 (1994) 2148.
- [40] S. Grard, Ph. Morin, M. Dreux, J.P. Ribet, *J. Chromatogr. A* 926 (2001) 3.
- [41] D.L.D. Deforce, F.P.K. Ryniers, E.G. Van den Eeckhout, F. Lemièrè, E.L. Esmans, *Anal. Chem.* 68 (1996) 3575.
- [42] J. Ding, P. Vouros, *Anal. Chem.* 71 (1999) 378A.
- [43] F. Foret, T.J. Thompson, P. Vouros, B.L. Karger, P. Gebauer, P. Boček, *Anal. Chem.* 66 (1994) 4450.

- [44] R.D. Smith, J.H. Wahl, D.R. Goodlett, S.A. Hofstadler, *Anal. Chem.* 65 (1993) 574A.
- [45] L. Fang, R. Zhang, E.R. Williams, R.N. Zare, *Anal. Chem.* 66 (1994) 3696.
- [46] A. Numan, N.D. Danielson, *Anal. Chim. Acta* 460 (2002) 49.

CHAPTER V

ELECTROPHORETIC SENSITIVITY ENHANCEMENT TECHNIQUES FOR THE ANALYSIS OF ANGIOTENSINS BY CAPILLARY ELECTROPHORESIS COUPLED TO TIME-OF-FLIGHT MASS SPECTROMETRY

V.1. INTRODUCTION

The renin-angiotensin system plays a major role in regulating sodium in humans and is important in maintenance of blood pressure and homeostasis in both normotensive individuals and those with cardiovascular disease, including systemic hypertension and congestive heart failure [1]. The effector substance of this system is angiotensin II (AII), an octapeptide. AII is among the most potent vasoactive compounds known. It increases blood pressure by direct vasoconstriction of the arterioles. It also acts indirectly by stimulating the synthesis and release of aldosterone from the adrenal gland [2] and the release of norepinephrine from sympathetic nerve terminals [3].

One of the many types of hypertension is renovascular hypertension which stems from a reduction in blood flow through the renal artery to one kidney due to the complete or partial stenosis of the renal artery. In renovascular hypertension there is a dramatic activation of the renin-angiotensin system [4]. In this setting AII is the mediator of increased blood pressure. Consequently, in order to provide appropriate therapy, it is critical to determine whether or not an individual with hypertension has an excess of AII, indicative of renovascular hypertension. Its treatment differs dramatically from treatment

of other forms of hypertension and misdiagnosis could lead to significant medical complications.

In the angiotensin synthetic pathway, a highly selective serine protease, renin, acts on its substrate, angiotensinogen, to form the biologically inactive decapeptide, angiotensin I (AI). AI is then cleaved by angiotensin converting enzyme to yield a 1-8 fragment, AII. Both AI and AII are rapidly degraded by various angiotensinases to several peptides, some of which still possess distinct biological activities. Angiotensin II(2-8), called angiotensin III (AIII), is a less potent vasoconstrictor than AII [5,6], but it retains complete activity for the stimulation of aldosterone secretion [7]. Angiotensin II(3-8), called angiotensin IV (AIV), has inhibitory, trophic and vasodilatory effects, opposite to AII [6]. Angiotensin I(1-7), AI(1-7), may also be physiologically active.

The concentrations of AII in plasma have been estimated to be between 5 and 100 pg/mL (~5-100 pM), but these levels may be increased by physiologic stimuli 10- to 25-fold. The half-life of AII in plasma is on the order of a few minutes. The plasma concentrations of AIII are about 20% of those of AII [1]. Due to the fact that angiotensins are present at such low concentration³ in plasma and tissues, they are most commonly measured by radioimmunoassay (RIA). Although RIA is a very sensitive method, it suffers from some serious limitations. This is especially so for the angiotensins. For example, antibodies raised against AI have been shown to have 100% cross-reactivity with AI(2-10) and AI(3-10). Antibodies specific for AII cross-react 100% with AIII, which is present in plasma at significant levels relative to AII, and also with AIV and A(4-8) [7]. Hence, existing radioimmunoassays for AI and AII are not specific and antibody assays are unavailable for smaller angiotensin fragments, even

those known to be biologically active. Antibody assays for AI or AII are also very time intensive, as they require incubation times ranging from several hours to two days.

In order to increase the specificity of the analysis of angiotensins by RIA, several researchers have employed solid phase extraction and/or HPLC purification of the sample prior to RIA [5,6,8,9]. However, the angiotensins are present at concentrations below the UV detection limits of the HPLC system, and hence the chromatographic column must be precalibrated with standards at UV-detectable concentrations. The appropriate sample fractions (often several) are then collected “blindly,” based solely on predetermined retention times, followed by drying and redissolving the eluates prior to RIA. This procedure is very labor intensive, time consuming, and susceptible to significant losses. Also, some angiotensin fragments present in the specimen might not be completely resolved from AI or AII, thus still allowing for compromised RIA results. Hence, these techniques are not suitable for routine analyses of clinical or research specimens.

Matsui et al. [10] developed a heart-cut column-switching HPLC technique with fluorimetric detection for the determination of AI, AII, AII(5-8), and AII(3-4). Using this technique, they achieved picomolar detection limits. However, the procedure involved derivatizing plasma ultrafiltrates with a fluorogenic reagent that was not specific for angiotensins followed by two chromatographic column separations. Only one angiotensin could be analyzed at a time and a different type of first column was required for AI and AII than for AII(5-8) and AII(3-4). The separation was said to be accomplished in under two hours, however, the total analysis time did not include the slow process of ultrafiltration and derivatization of the plasma sample. Therefore, this complex procedure is also unsuitable for clinical practice.

Fredline et al. [11] published an HPLC-ESI-MS/MS method for the determination of AI as a measure of plasma renin activity. The detection limits for this method were in the nanomolar range. The sensitivity of this method was sufficient for the detection of AI, after it had been greatly augmented by the continued activity of renin in an incubated plasma sample. However, the method was inadequately sensitive for the detection of endogenous angiotensin levels.

As demonstrated in Chapters III & IV and in the work of others, capillary electrophoresis (CE) has shown wide applicability to separations demanding high resolution while requiring only very small sample volumes [12,13]. However, as discussed in Chapter I, an often-cited drawback of CE is its high concentration limit of detection (cLOD), particularly apparent when conventional detectors such as ultraviolet/visible absorption (UV/Vis) or electrical conductivity are used for trace analysis. This is especially a problem for many biological specimens, where analytes, such as the angiotensins, are often present at concentrations below the detector cLOD, thus necessitating preconcentration of the analytes before their final separation and detection [14,15].

Various sample preconcentration methods are discussed in Chapter I. This study focuses on electrophoretic approaches to increasing CE sensitivity, namely field amplified injection (FAI) and isotachopheresis (ITP). These techniques are often simpler and more straightforward than sorption methods because they utilize mechanisms typical for CE, whereas chromatographic techniques introduce other mechanisms into the system making it more complicated to optimize [15].

FAI is based on the difference in electromigration velocity of the analyte in the sample plug and the velocity in the running buffer [16]. During FAI, the analytes are injected electrokinetically from a sample prepared in water or a highly diluted buffer. Upon the application of voltage, the electric field strength in the lower-conductivity sample is much higher than in the running buffer, which causes the ions present in the sample to migrate rapidly to the interface between the zones of lower and higher conductivity. As the analytes reach the interface, they encounter lower electric field strength, which causes an abrupt decrease in their velocities, forcing them to stack into a narrow zone [15,17,18]. The main advantage of FAI is the large (100 to over 1000-fold) sensitivity enhancement that can be achieved compared to pressure injection without sample stacking [19]. This is because this technique has theoretically no limited injection volume. The analyte ions in the given sample volume can be injected virtually exhaustively [16,15]. The drawbacks are the injection discrimination effects due to differences in electrophoretic mobilities of the analytes and the strong influence of matrix on the conductivity and, therefore, on the amounts of analytes injected. However, combined with effective sample preparation, FAI has been successfully used for sensitivity enhancement in peptide and tryptic digest analyses [20], and in validated assays of pharmaceuticals in biological fluids [21,22].

Similarly to CE, ITP separates the analyte bands according to differences in their electrophoretic mobilities [23]. However, ITP differs from CE in that it utilizes a discontinuous buffer system comprised of a leading electrolyte (LE) and a terminating electrolyte (TE). The LE and TE have electrophoretic mobilities that are higher and lower, respectively, than the analytes of interest in the sample. The sample is inserted

between the two electrolyte solutions and the analytes partition or stack in order of their electrophoretic mobilities (from highest to lowest) immediately after the LE zone. Once the zones reach their steady state, the entire system moves at constant velocity, hence the name “iso” for same and “tacho” for speed. The analyte concentration within each separated zone is determined by the concentration of the LE, which is typically more than 1000-fold higher than the predicted analyte concentrations in the initial sample. This means that ITP can increase analyte concentrations commonly by a factor of 100 to 1000, but as high as 10^6 for trace components [24]. However, it can also dilute bulk components to levels matching the concentration of the LE. ITP also has the capability of separating the analytes from potentially interfering substances having electrophoretic mobilities that do not lie within the range of the LE-TE pair. Compounds with mobilities that are greater than the LE, or smaller than the TE, do not migrate with the ITP stack, but are diluted in the LE or TE zones.

Although ITP can serve as a stand-alone separation technique for certain applications [25-27], it has some serious limitations. For qualitative and quantitative determinations, the detection method used must recognize the front and rear boundaries of the zone of interest [28]. This may be difficult when conventional UV or conductivity detectors are used, since the ITP zones are not separated from each other as peaks in CE, but follow one another “back-to-back” to maintain electrical continuity. Consequently, most ITP applications involve the determination of fairly concentrated analytes in relatively simple matrices; and despite the higher loading capacity advantage of ITP over CE, the detection limits in ITP are generally not sufficient for trace analysis. As Caslavská et al. [29] found from a comparative study of capillary ITP, CE and capillary

electrophoretic focusing, the ITP detection limits can approach those observed in CE only when the ITP spike technique (in which baseline-resolved UV absorption peaks of solutes are produced by bracketing the solute with discrete, nonabsorbing spacers) is applied. These limitations can be, to a large degree, overcome by using a detection technique capable of signal deconvolution, such as mass spectrometry [30,31]. The use of the mass spectrometer is also highly beneficial in instances where the amounts of analytes are insufficient to form fully developed ITP zones, because the detection and identification of analytes within the resulting sharp peaks or narrow mixed zones bracketed by normal ITP zones [24,32] using conventional detectors is rather problematic.

However, when several analytes elute from the column at the same time, signal discrimination and suppression in the electrospray ionization interface can occur [33]. This makes accurate quantitative measurements difficult if not impossible. A complicated solution to this problem would be the use of spacers that do not interfere with the ionization process [34,35]. A more generally applicable approach is coupling the high load ITP technique with a CE separation.

ITP-CE is usually performed in two configurations: on a single column [36-43] or on two capillaries coupled together [44-45]. However, three-column arrangements have also been used [46]. In the single column mode, also called transient ITP-CE, the same capillary is employed for both the ITP and the CE procedures. Transient ITP-CE can be done with or without sample matrix removal. Without removing the sample matrix, up to 30-50% of the capillary volume can be filled with sample without adversely affecting the separation efficiency. To further increase the sample volume, matrix removal must be employed. These procedures usually involve electroosmotic flow [18,47] or pressure-

assisted counterflow [39-42] in the direction opposite to the analyte migration. The advantages of the single column mode are relative simplicity, easy automation, and no requirements for modifications of existing instrumentation.

On the other hand, coupled column ITP-CE usually requires specialized instrumentation, which is most often built in-house and not commercially available. However, lower detection limits can be achieved because the ITP capillary can have a large internal diameter, thus having a greater sample capacity while the separation proceeds in a smaller diameter column suitable for CE. While most two-column ITP-CE methods utilize sample splitting or heart-cutting to discard a major portion of the sample to avoid column overloading, this work presents an on-line combination of capillary ITP preconcentration with CE separation in a comprehensive arrangement. With comprehensive ITP-CE, the entire sample is analyzed in a series of injections of portions of the focused ITP zones into the CE capillary [48,49].

The objective of this work was to explore various electrophoretic methods for sensitivity enhancement for the analysis of a family of angiotensin peptides by capillary electrophoretic separation coupled to TOFMS detection.

V.2. EXPERIMENTAL

V.2.1. Materials and chemicals

Fused silica capillaries (50 μm i.d., 187 μm o.d. or 365 μm o.d.; 75 μm i.d., 365 μm o.d.; 150 and 200 μm i.d., 365 μm o.d.) were purchased from Polymicro Technologies (Phoenix, AZ, USA). HPLC grade acetonitrile, methanol and triethylamine were purchased from Fisher Scientific (Fair Lawn, NJ, USA). Glacial acetic acid and

formic acid were obtained from EM Science (Gibbstown, NJ, USA). Ammonium acetate, ammonium formate and HPLC grade water were from Mallinckrodt (Hazelwood, MO, USA). Angiotensins, I, I (1-7), II, III and IV (AI, AI (1-7), AII, AIII and AIV), as well as polyvinylalcohol (PVA, 99+ %, average MW 89,000-98,000 g/mol) were purchased from Aldrich (Milwaukee, WI, USA). All buffers were degassed by sonication. Compressed nitrogen from Airgas (Salt Lake City, UT, USA) was used as a curtain gas to help desolvate compounds emerging from the electrospray interface.

V.2.2. Instrumentation

A commercial Crystal CE Model 300 (UNICAM, Madison, WI, USA) capillary electrophoresis apparatus was used for all separations. The separation columns were thermostated to 22 °C. For separations with UV/Vis detection, a Model 759 A UV absorbance detector (Applied Biosystems, Foster City, CA, USA) was used. Detection wavelength was set at 206 nm. ChromPerfect 3.54 Data Acquisition software (Justice Laboratory Software, Palo Alto, CA, USA) was used to collect data from the UV detector. A commercial Jaguar™ TOFMS (LECO, St. Joseph, MI, USA) with an in-house built liquid sheath electrospray interface, was used as the MS detector. MS data were collected with sum rates of 1600 and 3200, which resulted in 3.1 and 1.6 spectra/s, respectively. The nozzle board was heated to 80 °C. All instrumentation used in this work is described in detail in Chapter II.

V.3. RESULTS AND DISCUSSION

V.3.1. Separation of angiotensins using CE-UV

While AII has been used as a component of standard peptide mixtures for testing various electrophoretic separation schemes [40,41,50], the accounts of CE separations designed specifically for the analysis of the principal members of the angiotensin family linked to renovascular hypertension are scarce. Baars and Patonay achieved sub-nanomolar detection limits for six AI variants from different species after derivatization of a more concentrated solution of standards with a near-infrared fluorescent dye and subsequent dilution of the reaction mixture prior to CE separation [51]. Lim and Sim separated angiotensinogen and 9 of its proteolytic products (including AI, AII, AIII, AIV, and AI(1-7)) using CE with a mercury lamp as a strong UV light source at 185 nm [52]. They used this method to follow the degradation of exogenous AI to AII and AIII in a rat lung homogenate as well as for the analysis of human plasma. In spite of the stronger light source, the LOD's were in the low micromolar range, which is insufficient for the detection of endogenous plasma angiotensin levels even after the 40-fold SPE preconcentration they achieved. To accomplish the separation, phosphate based buffers, unsuitable for coupling with mass spectrometric detection, were used in both of the reports.

I have focused on designing separation schemes utilizing electrolytes suitable for use with mass spectrometric detection. PVA coated capillaries were used for all separations to eliminate the EOF and to reduce peptide adsorption to the walls. Volatile organic acid-based electrolytes were explored for the separation of AI, AII, AIII, AIV, and AI (1-7). As shown in Chapters III and IV, formic acid and acetic acid have worked

well for the separation of the catecholamine and indolamine families. When 0.5% (v/v) aqueous solution of formic acid (pH 2.23) was used for the separation of angiotensin standards, AIII and AI coeluted significantly, while the rest of angiotensins were well resolved (see Figure V.1A). Using acetic acid (1% (v/v), pH 2.7), overall resolution was better, but peaks were less intense, broader, and tailing significantly (see Figure V.1B). Because different analytes coeluted when the two acids were used individually, mixtures of formic and acetic acids, 0.3% / 0.1% (v/v) and 0.2% / 0.2% (v/v) were tested to find out whether they afford any improvement in resolution. Both mixtures yielded baseline separation of all analytes, with the latter giving a slightly higher overall resolution (Figure V.1C).

Next, ammonium formate and ammonium acetate were tested at varying pH values. Baseline separation and similar currents and migration times were obtained with both buffers between pH ~4-5, with the optimum being approximately in the middle of this range (see Figure V.1D). The separation efficiency (i.e., sharper peaks) was slightly higher in ammonium acetate. Although not much difference is observed when using formate or acetate buffers in CE separation, formate does have a significantly higher electrophoretic mobility than acetate, which means that the separation window using ITP-based preconcentration would be much shorter with formate-based buffers than with acetate buffers. This was confirmed by monitoring the speed of migration of the ITP boundary when the capillary was filled with the LE (ammonium acetate or formate) and the ITP process was started without sample injection with the corresponding TE (acetic or formic acid) at the inlet vial. While the ITP boundary appeared in just a few minutes with the formate buffer, the migration of the acetate/acetic acid boundary was

significantly slower (~13.5 min). This makes formate unsuitable for the sensitivity enhancement methods.

The concentrations of the electrolytes were chosen based on the i.d. and length of the separation capillary so as to provide sufficient ionic strength for the separation while limiting the Joule heating generated by excess current, i.e., CE current > 35 μ A.

Using pressure injection, a mixture of five angiotensins in water was analyzed at six different concentration levels from approximately 0.2 to 10 μ M to establish the concentration detection limits for simple CE-UV analysis. The results are summarized in Table V.1.

Table V.1. Regression equations, regression coefficients (R) and LOD's for CE-UV of angiotensin standards. Conditions: capillary, (53+11) cm, 50 μ m i.d., 360 μ m o.d., PVA coated; injection, 100 mbar/0.24 min; run voltage, 30 kV; BGE, 25 mM ammonium acetate, pH 4.5.

Angiotensin	Regression Equation	R	LOD (μ M)
A I	$y = 3E+09x + 17$	0.9997	0.27
A II	$y = 5E+09x + 38$	0.9994	0.16
A III	$y = 2E+09x + 75$	0.9991	0.19
A I (1-7)	$y = 2E+09x + 378$	0.9992	0.25
A IV	$y = 5E+09x + 46$	0.9992	0.14

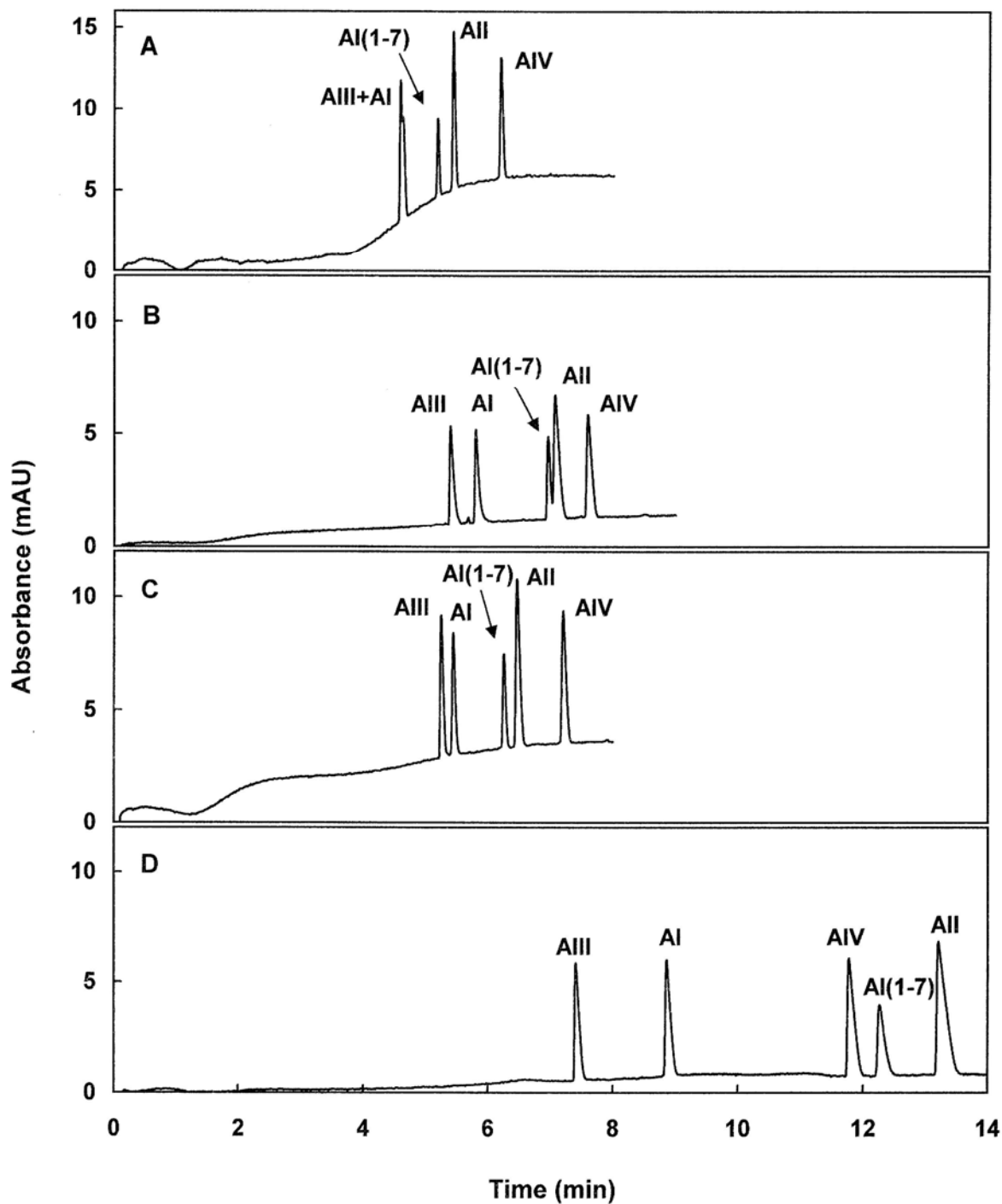

Figure V.1. CE-UV separation of a 10- μ M angiotensin mixture in different background electrolytes. Conditions: capillary, (54+11) cm, 75 μ m i.d., 360 μ m o.d., PVA coated; injection, 40 mbar/0.2 min; run voltage, 30 kV; λ =206 nm; sample in water. BGE: (A) 0.5% formic acid, pH 2.23; (B) 1% acetic acid, pH 2.7; (C) 0.2%/0.2% formic acid/acetic acid, pH 2.50; (D) 10 mM ammonium acetate, pH 4.5.

V.3.2. Separation of angiotensins using CE-TOFMS

As discussed in Chapter II, the use of capillaries with suppressed EOF necessitated the employment of a liquid sheath-flow electrospray ionization interface for the coupling of electrophoretic separations to mass spectrometric detection. Although not as sensitive as sheathless electrospray, the sheath-flow configuration has the advantages of ease of fabrication, reliability, robustness and versatility.

The m/z values and relative abundances (RA) of the angiotensin ionization products are provided in Table V.2. The major ion products of each peptide were assigned RA=100%. The RA of a minor product represents a fraction of the RA of a major ion of the respective angiotensin. In our experiments, the main ionization products were doubly (AII, AI(1-7), AIII, AIV) and triply (AI) charged ions. The MS spectra of AII and AIII angiotensins contained only the doubly charged ions as predicted. AI(1-7) ionized almost completely as a doubly charged ion with a minor peak of a triply charged ion (< 3% RA). The spectrum of AI showed, in addition to a major peak for the predicted triply charged cation, a smaller peak (40% RA) of a doubly charged cation. In the case of AIV, the predicted singly charged ion represented a minor peak in the spectrum (~20%), whereas a doubly charged ion was the dominant one. These results are (with the exception of AIV) in agreement with the charges expected on the analytes under the acidic conditions of the liquid sheath and electrolytes employed in this study. They are also consistent with the results published by Lazar et al. [53].

A 0.2%/0.2% mixture of acetic and formic acids, as well as ammonium acetate, pH 4.5, at 2.5, 12.5, and 25 mM concentrations were tested as BGE for the coupling of capillary electrophoretic separation to TOFMS detection for the analysis of mixtures of angiotensin standards.

The composition of the liquid sheath used with the acetic/formic acid BGE was 70:30:0.1:0.1 (v/v) methanol/water/acetic acid/formic acid to match the composition of the BGE to prevent any potential adverse effects of the moving boundaries formed by mismatch between the electrophoretic mobilities of the counter ions from the liquid sheath and the BGE. Compared to the generally similar signal intensities obtained with UV detection, the MS peak intensities of the individual angiotensins differed significantly (Figure V.2A). While the detection limits of AII, AIII, and AI(1-7) were on the order of 0.1-0.2 μM , the S/N ratio for AIV at that concentration was greater than 10, and AI was barely detectable at about 3 μM concentration. Such detection limits would be sufficient for the analysis of peptides in tryptic digests of proteins, especially after SPE preconcentration, however, they are several orders of magnitude higher than needed for the analysis of endogenous angiotensin plasma levels. The signal intensity obtained with the acetic/formic acid BGE is approximately three times higher than that achieved with ammonium acetate buffers. However, the acetic/formic acid solution is not suitable for any of the above described preconcentration schemes, because it cannot be used as the BGE after the ITP preconcentration, nor does it afford any significant increase in sensitivity using FAI. Therefore this electrolyte was not considered in later studies.

It is well known that high concentrations of ionic species in the electrospray, e.g., from the separation electrolyte, tend to decrease the analyte signal [54]. When 25 mM ammonium acetate, pH 4.5, was used, it was found, as mentioned above, that the analyte signal was about three times lower than previously obtained with the acetic/formic acid BGE (Figure V.2B). Therefore, the ammonium acetate buffer was tested at 12.5 and 2.5 mM concentrations (Figures V.2C and V.2D). In either case the signal was not

significantly greater than obtained with the 25 mM concentration. With the lowest buffer concentration (2.5 mM), the peaks were very wide and the separation of the last three peaks was no longer baseline (Figure V.2D). The 12.5 mM ammonium acetate gave very clean electropherograms with good efficiencies (Figure V.2C). The spray seemed to be more stable than with the 25 mM buffer and the ionic deposits did not accumulate as quickly on the interface plate, which in turn did not need to be cleaned as often to prevent electric discharge between the ESI needle and plate. Therefore, the 12.5 mM buffer was used for all remaining separations.

Two liquid sheath compositions were tested for use with the acetate BGE: 70:30:0.2 (v/v) methanol/water/formic acid and 70:30:0.2 (v/v) methanol/water/acetic acid. The CE separation was similar in both cases, however, the formic acid liquid sheath seemed to facilitate a slightly higher analyte signal and cleaner background (not shown). The detection limits obtained with 12.5 mM ammonium acetate as BGE and formic acid liquid sheath were 0.3-0.5 μM for all angiotensins except AI (LOD \sim 4 μM), which again had the weakest signal.

Table V.2. Charge states, m/z ratios and relative abundances (RA) of angiotensin ions.

Charge	AIII		AI		AIV		AI (1-7)		AII	
	m/z	RA	m/z	RA	m/z	RA	m/z	RA	m/z	RA
1+	-	-	-	-	775.9	20%	-	-	-	-
2+	466.0	100%	648.3	40%	388.0	100%	450.0	100%	523.6	100%
3+	-	-	432.7	100%	-	-	900.0	<3%	-	-

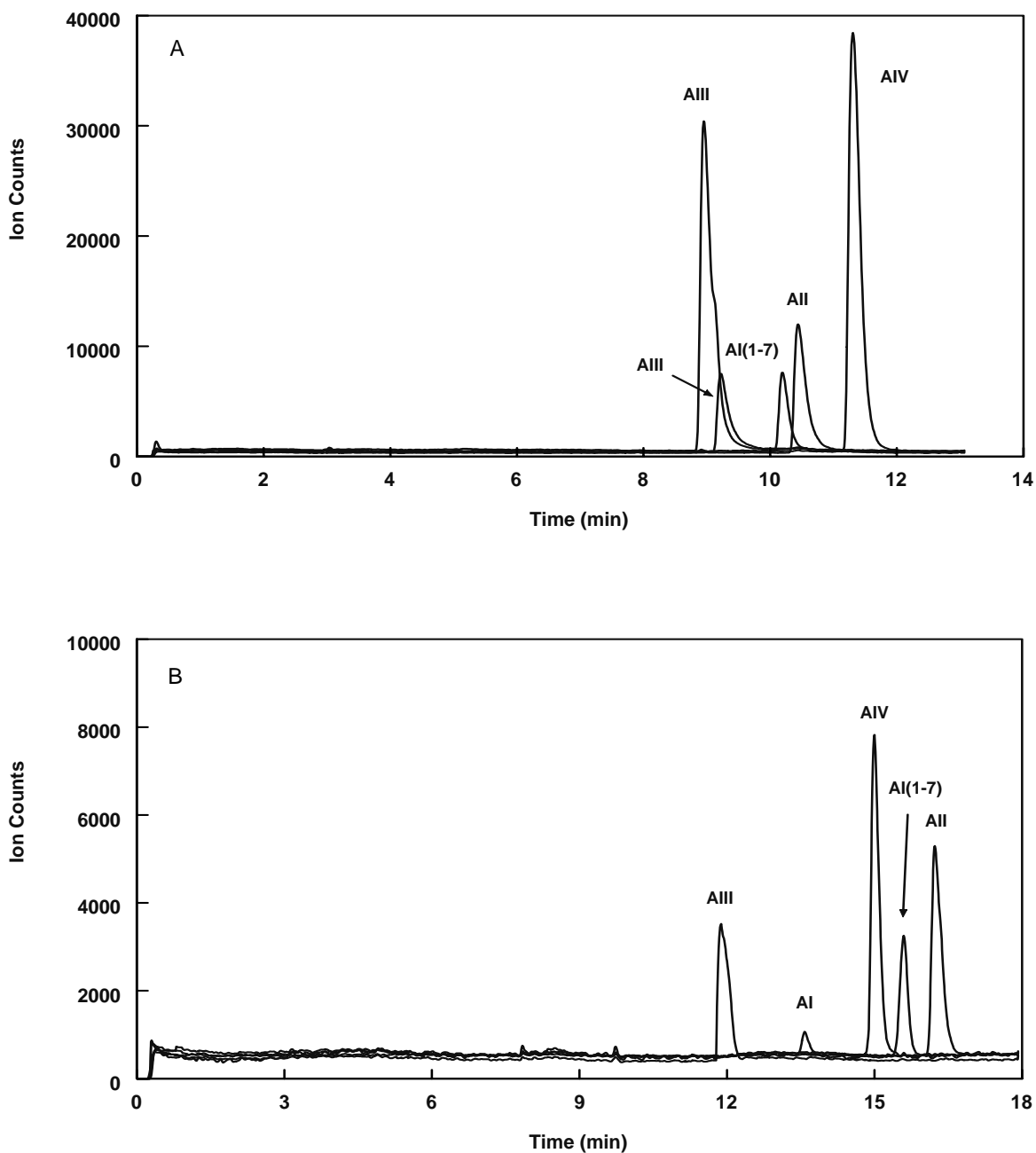

Figure V.2. CE-TOFMS separation of a 10- μ M angiotensin mixture in different background electrolytes. Conditions: capillary, 65 cm PVA, 50 μ m i.d., 360 μ m o.d.; injection, 100 mbar/0.24 min; run voltage/pressure, 27 kV/10 mbar; liquid sheath, 70:30:0.1:0.1 methanol/water/ formic acid, 1.7 μ L/min. BGE: (A) 0.2%/0.2% (v/v) aqueous formic acid/acetic acid, pH 2.5; (B) 25 mM ammonium acetate, pH 4.5.

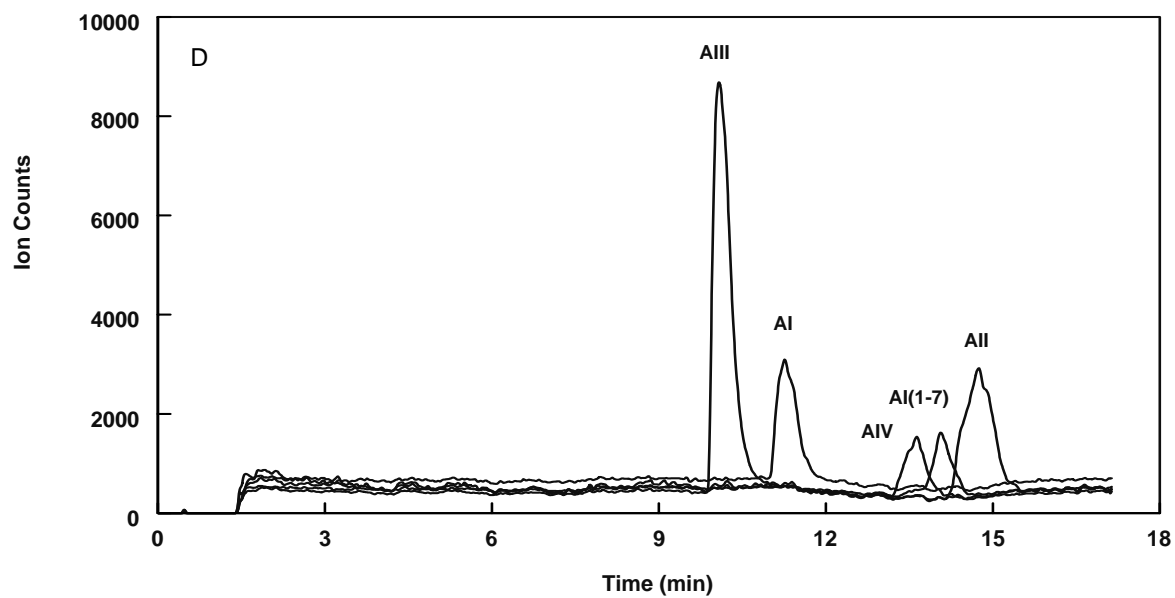
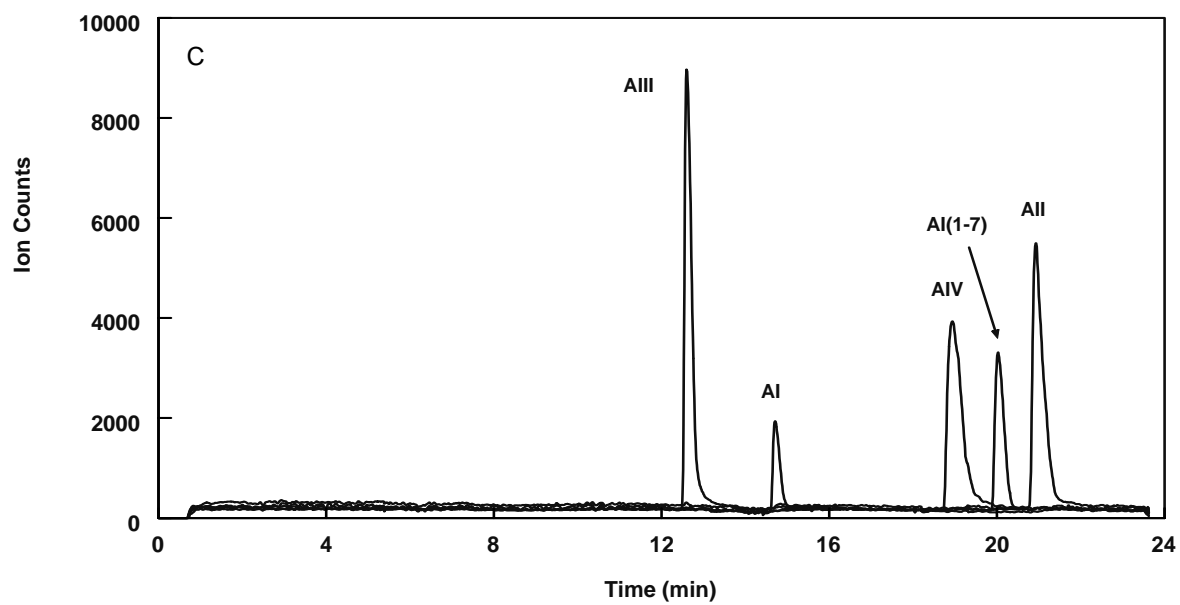

Figure V.2. Continued - BGE: (C) 12.5 mM ammonium acetate, pH 4.5; (D) 2.5 mM ammonium acetate, pH 4.5.

V.3.3. Separation of angiotensins using ITP-UV

Using ITP, the disadvantages of the limited sample capacity of CE can be overcome. However, due to the rectangular, zone-like appearance of the ITP signal, its processing is not as straightforward as that of the CE signal. For both qualitative and quantitative analysis, the detection technique used must recognize the front and rear boundaries of the zone of interest [28]. Figure V.3 shows a typical ITP-UV analysis of a sample containing five model angiotensin peptides at 30 μM concentrations. As can be seen in this figure, it was not possible to distinguish the boundaries of all of the individual zones. While there was some indication of the separation of the zones of AIII, AI, and AIV, it was not clear whether AI (1-7) and AII had very similar absorption coefficients or the zones were not completely separated from each other. Similar questions arise with the use of conductivity detection. While there have been reports describing evaluation of both the conductivity and UV detection signals by combining commercial chromatographic software with a code for handling the step-like isotachopherogram [29], this approach is not common.

V.3.4. Separation of angiotensins using ITP-TOFMS

It is obvious from Figure V.4A that much more information can be obtained on both the qualitative and quantitative composition of a stack of ITP zones using an information-rich detection technique such as mass spectrometry. Each zone was clearly defined based on the unique mass-to-charge ratios of the individual angiotensins.

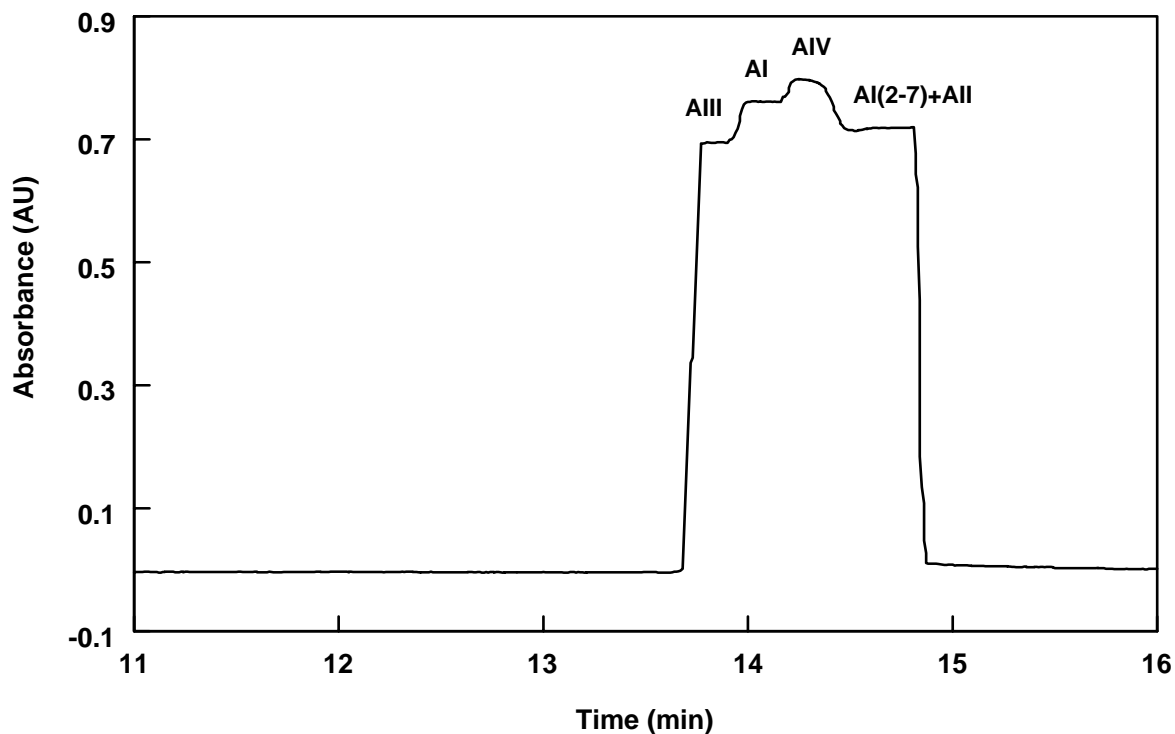
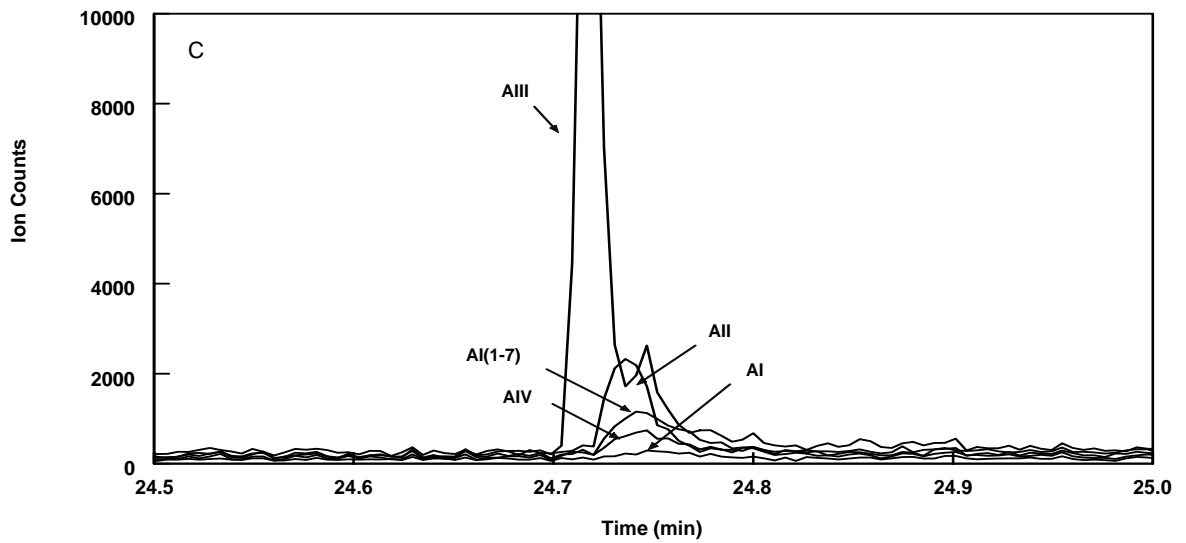
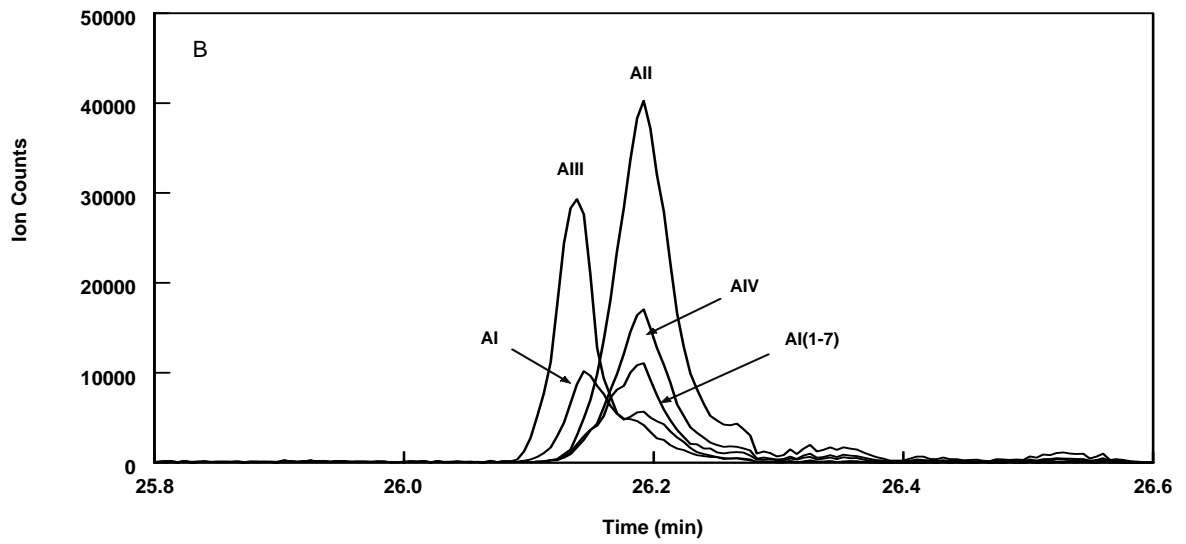
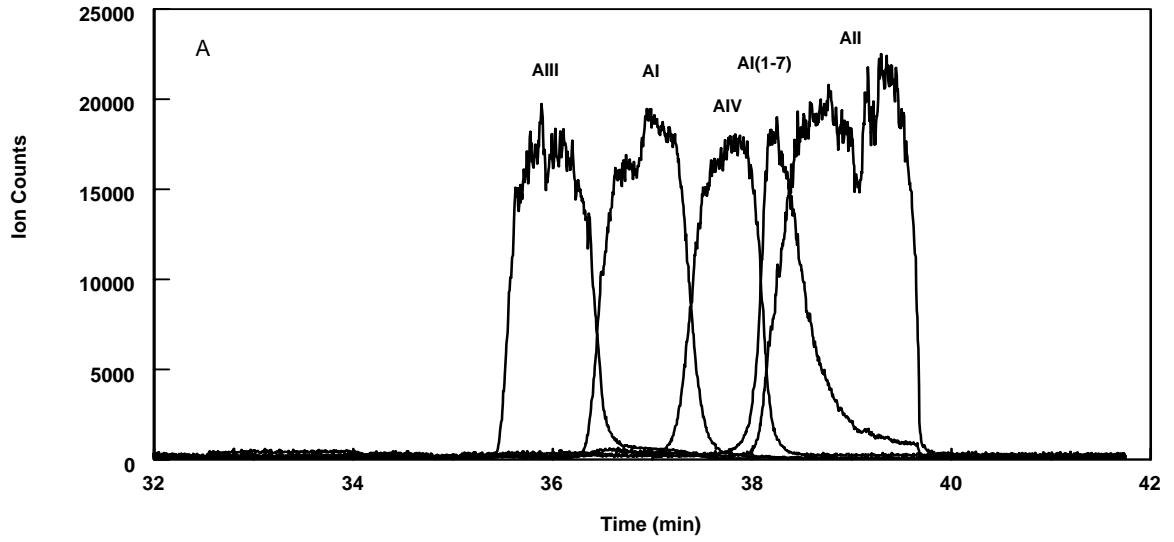

Figure V.3. ITP-UV separation of a 30 μM mixture of angiotensins. Conditions: capillary, (70+12) cm PVA, 150 μm i.d.; LE, 10 mM ammonium acetate; TE, 10 mM acetic acid; injection, 20 cm sample plug (50 mbar, 0.8 min); separation voltage, +30 kV for 13 min, +15 kV for remainder of the run.

Figure V.4. ITP-TOFMS of mixtures of angiotensins of decreasing concentrations. Conditions: capillary, 82 cm PVA, 150 μm i.d.; LE, 10 mM ammonium acetate; TE, 10 mM acetic acid; injection, 20 cm sample plug (50 mbar, 0.8 min); ITP separation voltage, 30 kV for 15 min, 15 kV for remainder of the run; liquid sheath, 70:30:0.1 methanol/water/acetic acid, 1.5 $\mu\text{L}/\text{min}$; ESI voltage, 4 kV; TOFMS interface plate temperature, 80 $^{\circ}\text{C}$. It should be noted that the presence of the ES voltage lowers the effective separation voltage, thus, increasing the migration times. Sample concentration: (A) 30 μM ; (B) 3 μM ; (C) 0.3 μM . (Figures on next page.)



Unlike UV detection, TOFMS detection made it apparent that the ITP conditions used had not allowed the system to reach steady state with complete separation of the zones. The last two zones, which represent AI (1-7) and AII, were only partially separated from each other. Thus we can see that mass spectrometry not only provides an excellent means of detection and identification of the typical flat-top ITP zones but can also serve as a tool for monitoring the migration behavior and the extent of separation of the analytes in ITP.

When flat-top ITP zones were present, quantitation was relatively straightforward, since the length of each zone relates directly to the absolute quantity of a particular analyte. Such classical ITP has proven to be a valuable tool in the control of the composition and purity of drug preparations [28] and in similar applications where the analysis is not limited by the sample size and concentration and the matrix is not very complicated. It has been more difficult to use ITP for the analysis of drugs or biomarkers in biological fluids, since the sample matrix often contains high concentrations of ionic components and the amount of analyte is too low to create a fully developed, flat-top ITP zone long enough for reliable detection. The ITP separation of a mixture of 3 μM angiotensin standards in Figure V.4B demonstrates that when the analyte concentrations in the analyzed volume were too low, the typical ITP zones started to collapse into peak-shaped mixed zones. It was not possible to analyze such a zone using traditional UV or conductivity detectors. TOFMS on the other hand, identified all analyte peaks present, even if the peaks were substantially overlapping. However, when several analytes are delivered into the electrospray at the same time, ion suppression and discrimination can occur. This phenomenon is apparent in Figure V.4C, which shows an ITP separation of

five angiotensins in the same injection volume as in Figure V.4A, but now at a concentration of 0.3 μ M each. Under these conditions, ionization of other angiotensin ions in the sample was greatly suppressed by AIII. The extent of ion suppression and discrimination depends on the relative concentrations of the compounds within the mixed zone and the analyte ionization efficiencies under the conditions used. Consequently, while MS detection offers a qualitative description of even complicated mixed zones, its ability to quantitate the analytes within the zone may be compromised. Additionally, some components of the sample may ionize with the same m/z ratio and, thus, without sufficient electrophoretic separation, the mass spectrometer may fail to identify such compounds as distinct entities [31].

V.3.5. Preconcentration methods for CE analysis of angiotensins with UV detection

Using ITP, significantly higher sample amounts can be loaded onto the column than in CE. However, the fact that the individual separated analyte zones migrate in a contiguous manner poses, as discussed above, some serious limitations for both UV and MS detection. These shortcomings can be eliminated to a large degree by combining the high sample capacity and concentration capability of ITP with the high separation efficiency of CE. In this study, the combination of ITP and CE was investigated in both single-column (transient ITP-CE) and coupled-column (comprehensive ITP-CE) arrangements. In addition to ITP, field amplified injection was another electrophoretic preconcentration method evaluated for the improvement of angiotensin detection limits obtained using CE-UV. Each of these approaches will be considered individually.

V.3.5.1. Field amplified injection

Using 10 mM ammonium acetate as the BGE in a 75 μm i.d., 64 cm long capillary, and a short 0.2-min injection at 20 kV, very good signal was obtained from a 50 nM angiotensin mixture in water. Using the same conditions, however, a 5 nM sample gave no peaks. When the injection time was increased to 1 min at the same voltage, the peaks were barely detectable. By increasing the injection time to 5 min, some of the fast migrating impurities were further concentrated, however, a very intense sharp peak appeared very early in the electropherogram, after which no other peaks were observed. The origin of the sharp peak is not entirely clear, but it closely resembles a zone boundary characteristic of isotachophoretic separation. It is possible that some isotachophoretic phenomena were occurring during the electrokinetic injection.

Interestingly, when a 10 \times diluted BGE was used as a sample matrix instead of water, it was possible to lengthen the injection times significantly (to up to 6 min), before the appearance of the ITP-like peak interfered with analyte separation and, thus, increase the amount of analyte injected. Burgi and Chien [55] reported the use of 10 \times diluted BGE, rather than water, as an optimum sample matrix for stacking of a long, gravity-injected sample plug. When sample was dissolved in 10 \times diluted BGE, the peaks were better separated and sharper than for the same sample in water. The improvements they observed, however, pertained to the quality of the separation, rather than to signal enhancement. They hypothesized that the improvements were due to the reduction of laminar broadening associated with inhomogeneities in electroosmotic flow when water was used as the matrix. It is not entirely clear why the presence of diluted buffer in the

sample during the FAI facilitates signal improvements compared to injecting analytes dissolved in water.

As mentioned earlier, electrokinetic injection with 0.2%/0.2% mixture of acetic and formic acids as the separation electrolyte did not afford any improvement in detection limits. At concentrations below 1 μM , no peaks were detected and with 1 μM samples, whether in water or in 10 \times diluted BGE, the analyte zones migrated as very broad, non-Gaussian peaks. This is understandable in light of the chemical properties of the organic acids: they are only partially dissociated in water and therefore the ionic strength of the solution as well as the apparent electrophoretic mobility of the hydrogen (co-ion to the angiotensins) are low. Consequently, the faster moving angiotensins do not stack up into a sharp zone against the boundary between the sample and the BGE, as they would in the case of buffers with higher ionic strength and faster co-ions, but form diffuse, “table-top” like zones.

Using a 50 μm i.d., 64 cm long capillary and 25 mM ammonium acetate, pH 4.5, as BGE, it was possible to increase the injection voltage and time to 25 kV and 10 min, which translates into higher amounts of sample injected into the capillary. Although the detection pathlength on a 50 μm i.d. capillary is smaller, the detection limits were comparable to or lower than those achieved for 75 μm i.d. capillary. This is because the BGE concentration that can be used with 50 μm i.d. capillary without generation of excessive Joule heat is at least 2 \times higher than that acceptable for a 75 μm i.d. capillary. With higher buffer concentration, higher voltage and/or longer time can be used for sample injection before the ITP-like peak interferes with angiotensins separation. Upon comparing Figures V.5A and V.5B, it can be seen that a similar signal intensity was

obtained from CE-UV analysis of $\sim 1 \mu\text{M}$ angiotensin mixture as from FAI-CE-UV analysis of about $300\times$ less concentrated sample ($\sim 3 \text{ nM}$).

To establish the linearity of this method, angiotensin mixtures in the concentration range from subnanomolar to $\sim 0.02 \mu\text{M}$ were injected into the CE capillary electrokinetically at 25 kV for 10 minutes, followed by a CE separation at 30 kV. The regression equation, regression coefficient and LOD's are given in Table V.3.

Table V.3. Regression equations, regression coefficients (R) and LOD's for FAI-CE-UV of angiotensin standards. Conditions: capillary, (53+11) cm PVA, $50 \mu\text{m}$ i.d., $360 \mu\text{m}$ o.d.; injection, 25 kV/10 min; run voltage, 30 kV; BGE, 25 mM ammonium acetate, pH 4.5.

Angiotensin	Regression Equation	R	LOD (nM)
A I	$y = 9E+11x + 79$	0.9990	0.5
A II	$y = 1E+12x + 2162$	0.9995	1.1
A III	$y = 9E+11x + 365$	0.9996	0.8
A I (1-7)	$y = 5E+11x + 922$	0.9996	1.5
A IV	$y = 1E+12x + 2586$	0.9995	0.9

V.3.5.2. Transient ITP-CE-UV without sample matrix removal

The second approach involved transient ITP-CE without sample matrix removal. In transient ITP-CE, 30-50% of the capillary can usually be filled with the sample [36]. The maximum sample volume that can be injected depends on the effective length of the capillary and on the buffer and sample concentrations. The effective length of the capillary left after sample injection must be sufficient for both ITP focusing and complete

CE separation. Injecting a longer sample plug not only physically shortens the separation length available, but also increases the ITP focusing time, because the migration of the forming ITP zones further reduces the length of capillary available for CE.

Generally, in the first step of the procedure, the capillary is filled with the LE. In our experiments, the LE was also used as a BGE. After the sample diluted in TE was pressure injected into the capillary, the inlet end of the capillary was immersed in the TE. Then the voltage was turned on and ITP focusing began. Finally, the inlet vial with TE was replaced with the LE/BGE vial and CE separation started, during which the sample, concentrated into narrow ITP zones, destacked and separated into individual CE zones.

In order to analyze the injected sample zone quantitatively, it is crucial to determine the appropriate ITP focusing time. This was done by monitoring the peak areas as a function of the focusing time [56,57]. The peak areas increased until they reached a plateau. Increasing the ITP focusing time past the plateau is undesirable, because it shortens the length of capillary available for destacking and CE separation. This results in decreased resolution and eventually in incomplete destacking of the slower migrating species.

Both 50- and 75- μm i.d. capillaries of various lengths were tested for the transient ITP-CE separation. While longer capillaries have a higher sample capacity, and therefore yield better LOD's, this improvement comes at the expense of speed of analysis, because the focusing and separation times are much longer. Also, with longer migration times, the influence of band broadening factors on the analyte zones is greater and thus the resulting peaks are broader, i.e., have lower signal-to-noise ratio, which adversely affects quantitation. A similar trade off exists between using 50- μm vs. 75- μm i.d. capillaries.

As in the case of FAI, the length of the separation window depends on the concentration of the electrolytes present in the capillary. The higher the concentrations of the LE and TE, the longer the sample plug that can be injected. Therefore, while 75- μm i.d. capillaries have larger volumes than 50- μm capillaries of the same length, higher concentration buffers can be used with the smaller diameter capillaries, allowing for longer sample plugs to be injected.

It was also observed that the concentration of the sample matrix, in our case the TE, had an effect on the width of the separation window. The ITP boundary following the angiotensin zones, which also represented the end of the separation window, was the farthest from the last angiotensin peak, or in other words, migrated the slowest, when the sample was dissolved in 2 \times diluted TE.

The peaks obtained with ITP-CE were broader than when using FAI and not as well resolved, because the length of capillary available for CE separation after transient ITP was shorter than with FAI. From comparing Figure V.5C with Figures V.5A and V.5B, it is obvious that the preconcentration power of ITP-CE is lower than that of FAI. However, the signal obtained is more representative of the composition of the sample because no discrimination effects occur during pressure injection.

Angiotensin mixtures at concentrations ranging from about 7 nM to 0.25 μM were analyzed by transient ITP-CE-UV on a 50- μm i.d., 64-cm PVA capillary with 25 mM ammonium acetate, pH 4.5, as the LE/BGE and 20 mM acetic acid as the TE. Approximately 30% of the capillary was filled with sample dissolved in 10 mM acetic acid. The regression equation, regression coefficient and LOD's are given in Table V.4.

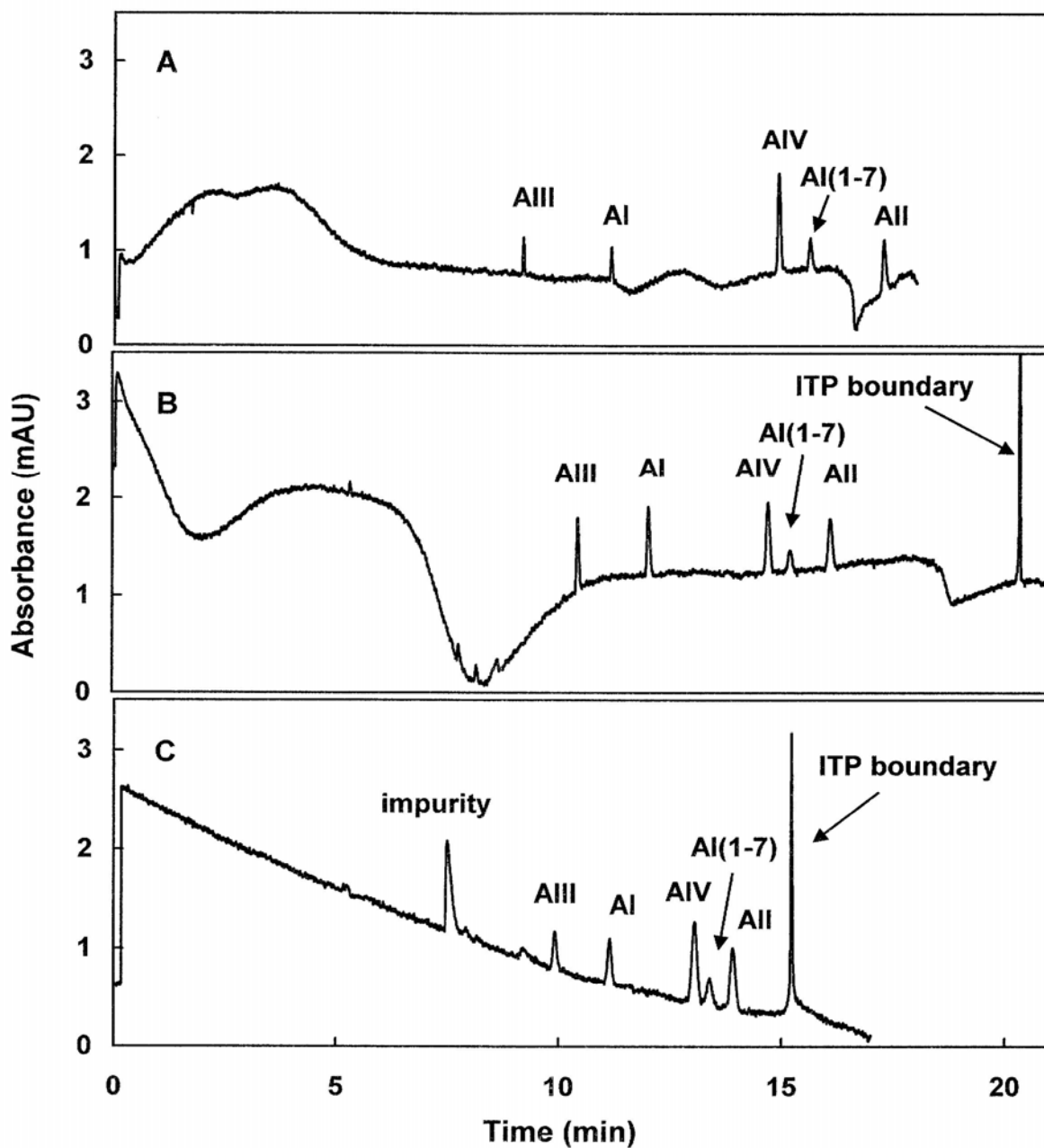

Figure V.5. Comparison of CE-UV, FAI-CE-UV and ITP-CE-UV analysis of angiotensin mixtures. Conditions: capillary, (53+11) cm PVA, 50 μm i.d., 360 μm o.d.; LE/BGE, 25 mM ammonium acetate, pH 4.5; TE, 20 mM acetic acid. (A) CE-UV of ~ 1 μM angiotensin mixture. Injection, 88 mbar/0.2 min; run voltage, 30 kV; BGE, 25 mM ammonium acetate, pH 4.5; sample in water. (B) FAI-CE-UV of ~ 3 nM angiotensin mixture. Injection, 25 kV/10 min; run voltage, 30 kV; sample in 2.5 mM ammonium acetate. (C) ITP-CE-UV of ~ 30 nM angiotensin mixture. Injection, 200 mbar/1.35 min; ITP focusing, 20 kV/3.5 min; CE voltage, 30 kV; sample in 10 mM acetic acid.

Table V.4. Regression equations, regression coefficients (R) and LOD's for transient ITP-CE-UV of angiotensin standards. Conditions: capillary, (53+11) cm PVA, 50 μ m i.d., 360 μ m o.d.; injection, 200 mbar/1.35 min; ITP focusing, at 20 kV for 3.5 min; run voltage, 30 kV; LE=BGE, 25 mM ammonium acetate, pH 4.5; TE: 20 mM HAc. Sample in 10 mM acetic acid.

Angiotensin	Regression Equation	R	LOD (nM)
A I	$y = 1E+11x + 130$	0.9987	6.9
A II	$y = 2E+11x + 439$	0.9997	7.0
A III	$y = 1E+11x + 56$	0.9999	10.2
A I (1-7)	$y = 9E+10x + 225$	0.9995	12.9
A IV	$y = 2E+11x + 289$	0.9998	9.0

V.3.5.3. Counterflow ITP-CE-UV

To further increase the amount of angiotensins applied to the separation column, I employed a modified ITP-CE-UV technique utilizing counterflow of LE to facilitate sample matrix removal.

Sample volumes as much as 90% of the capillary volume can be injected in ITP-CE if there is a way to remove a substantial portion of the sample matrix which would otherwise interfere with CE separation. EOF traveling in a direction opposite to sample

migration has been used to reduce the matrix volume in uncoated silica capillaries or in capillaries with walls modified by charged polymers [18,47]. For neutrally coated capillaries and/or when the direction of analyte and EOF migration is the same, pressure can be used for the same purpose [39-42]. Because manipulating pressure is easier than working with EOF and because our instrument has the capability of applying both positive and negative pressure in combination with separation voltage, I chose to use a pressure-generated counterflow as a means of removal of sample matrix.

Using this approach, a significant portion, theoretically 100%, of the capillary can be filled with sample. In practice, up to 90% of the capillary volume can be filled without any sample losses during ITP focusing [39]. Optimization of parameters for counterflow ITP-CE is more complex than for simple transient ITP-CE. With most of the capillary filled with sample, voltage and counterflow pressure values as well as focusing times must be chosen in such a way as to prevent analyte losses from either end of the capillary.

Once the sample is injected and the inlet end immersed in TE, ITP focusing begins. Initially, it is beneficial to apply voltage only (no counterflow) for a short period to allow the sample/TE boundary to move into the capillary, well away from the inlet. This step protects the unfocused sample from being pushed out of the inlet end of the capillary. Next, negative pressure is applied together with a focusing voltage. The forming ITP zones are carried to the inlet end of the capillary. A convenient way to track the removal of the sample matrix is by monitoring the current during the ITP focusing step [38,39]. At constant focusing voltage and when the leading electrolyte is used as background electrolyte, the current increases as more of the LE is drawn into the

capillary through the outlet end. The ITP focusing is switched to CE separation by replacing the TE vial at the inlet with an LE vial, usually when the focusing current reaches 80-90% of the value measured with the whole capillary filled with LE [38,39].

In work done by Chen et al. [58], a mixture of five angiotensins was focused for one minute before applying counterflow and ITP focusing was switched to CE separation at 90% of the LE current. I have explored several different voltage/counterflow combinations. When conditions similar to Chen et al. were used with a 50 μm i.d. capillary, the three last-eluting angiotensins had proportionally lower signal intensities than those obtained with CE analysis of a higher concentration sample with the same angiotensin ratios. This means that a portion of the sample plug, especially of the slower migrating species, must have been lost from the capillary inlet before the ITP focusing was complete. I also found that while increasing the counterflow-focusing times produced higher peak efficiencies and improved the overall separation, it also caused a decrease in the analyte signal, both peak areas and peak heights. Because this phenomenon was occurring at currents much lower than 90% of the LE current, it could be assumed that the decrease in signal is not related to analyte loss out the capillary inlet. Also, decreasing the separation voltage increased the peak areas without significantly decreasing the peak heights. These phenomena are consistent with the fact that the UV detector is a concentration sensitive detector.

Therefore, I found it advantageous to increase the time of the initial voltage-only focusing and to shorten the focusing with counterflow in order to maximize the signal intensity. The focused zones were pushed into the capillary only far enough to obtain reasonable CE separation. This also reduced the overall focusing time and, therefore, the

total analysis time. Although using the counterflow to increase the loading capacity of the ITP-CE technique further improves the detection limits, the improvement was only about two- to three-fold, compared with simple transient ITP-CE. Also, the counterflow ITP-CE setup requires the presence of an outlet vial which would necessitate modifications of the existing instrumentation if this method were to be used with TOFMS detection. Therefore, counterflow ITP-CE was not used for coupling with TOFMS.

V.3.6. Single-capillary preconcentration techniques coupled to TOFMS

When the preconcentration techniques described in Sections V.3.5.1 and V.3.5.2 were coupled to mass spectrometric detection and a formic acid liquid sheath solution was used, it was observed that while AIII and AI were well resolved from each other and from the other peaks, the last three peaks coeluted completely (in transient ITP-CE) or were minimally resolved (in FAI). The AIV, AI(1-7) and AII peaks were also much narrower, showing more isotachophoretic than electrophoretic character (see Figures V.6 and V.7). It is known that with MS detection, especially when using a liquid sheath interface, the separation efficiency and resolution are lower than for the same separation done with UV detection [15]. Therefore, a longer capillary (80 cm) was used to repeat the ITP-CE separation performed previously on a 65-cm capillary. Nevertheless, even with a 15 cm longer capillary, there was little or no improvement in the resolution of the last three peaks in both ITP-CE and FAI-CE (not shown).

Another possible explanation for the observed phenomenon was the use of a lower concentration electrolyte system (12.5 mM ammonium acetate as LE/BGE and 10 mM acetic acid as TE) than in the case of UV detection (25 mM ammonium acetate as

LE/BGE and 20 mM acetic acid as TE), which does lead to earlier migration of the ITP boundary and closes the separation window. To find out how close the ITP boundary would be to the slowest migrating peak with a given column length and electrolyte concentrations, the separation conditions used with MS detection were simulated as closely as possible with UV detection. This included matching the effective column length, i.e., the distance to the UV detector, to the total MS column length, and using the same electric field strength (V/cm) and electrolyte concentrations. In both ITP-CE-UV and FAI-CE-UV, the ITP boundary was far enough from the last angiotensin peak to allow for a complete separation of the last three peaks.

As monitored with UV detection, further slowing of the migration of the ITP boundary and, thus, widening of the separation window can be accomplished by adding methanol to the separation electrolytes and sample matrix. This approach, however, worked only for ITP-CE where the amount injected was not current dependent. When increasing amounts of methanol were added into the separation buffer, the current decreased even at constant electrolyte concentration. This means that for the same injection time and voltage in FAI, the ITP boundary migrated slower in the methanolic buffer than in the aqueous buffer, but the amount of analyte injected was also lower. In order to increase the analyte amount loaded on column, it is necessary to increase the injection time and/or voltage which, however, brings the ITP boundary closer to the analyte peaks. Clearly, the addition of organic phase into the BGE is counterproductive for FAI. Nevertheless, even with the use of methanolic buffers, there was no improvement in the separation for ITP-CE coupled to MS.

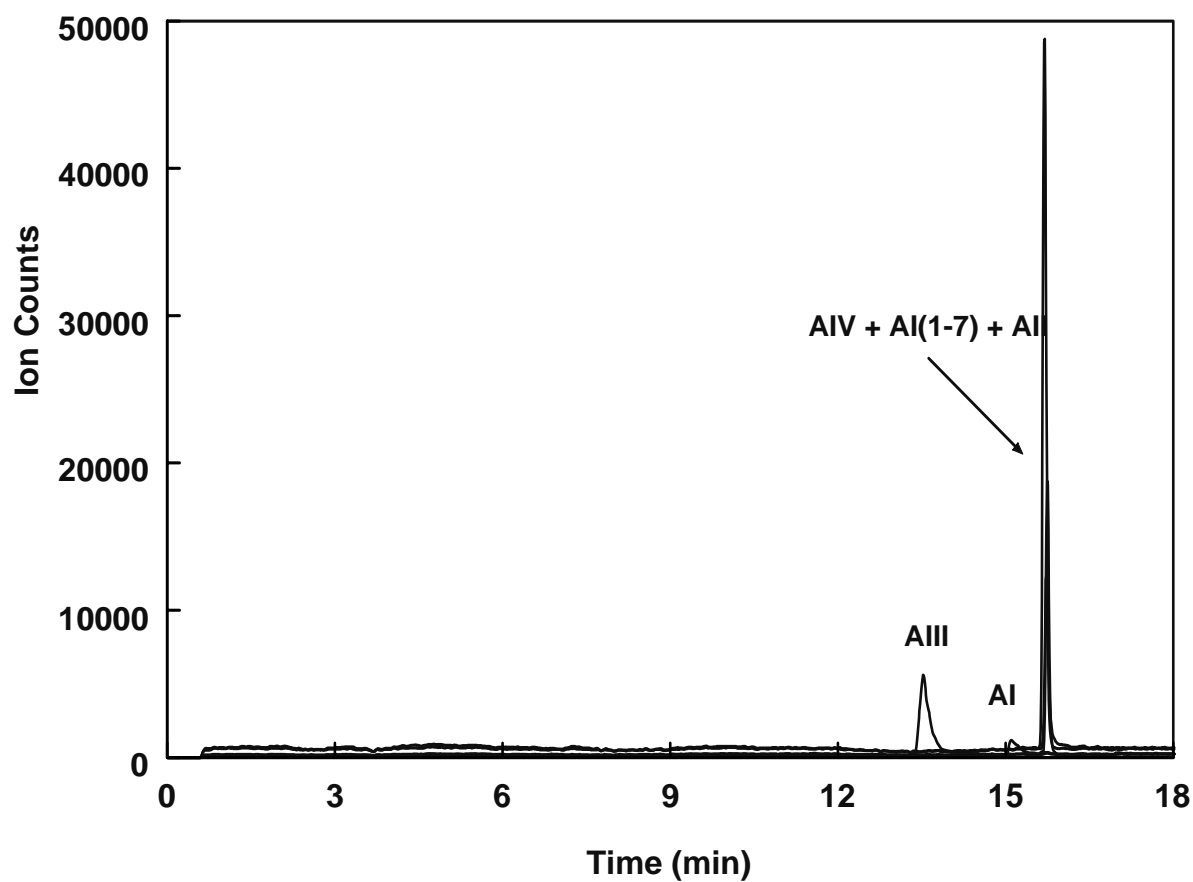

Figure V.6. ITP-CE-MS analysis of 1 μM angiotensin mixture. Conditions: capillary, 65 cm PVA, 50 μm i.d., 360 μm o.d.; injection, 100 mbar/3 min (~30% fill); ITP focusing, 20 kV/3.5 min; CE voltage, 30 kV; LE/BGE, 12.5 mM ammonium acetate, pH 4.5; TE, 10 mM acetic acid; sample in 5 mM acetic acid. ESI voltage, 3300 V; liquid sheath, 70:30:0.2 methanol/water/formic acid, 2.0 $\mu\text{L}/\text{min}$.

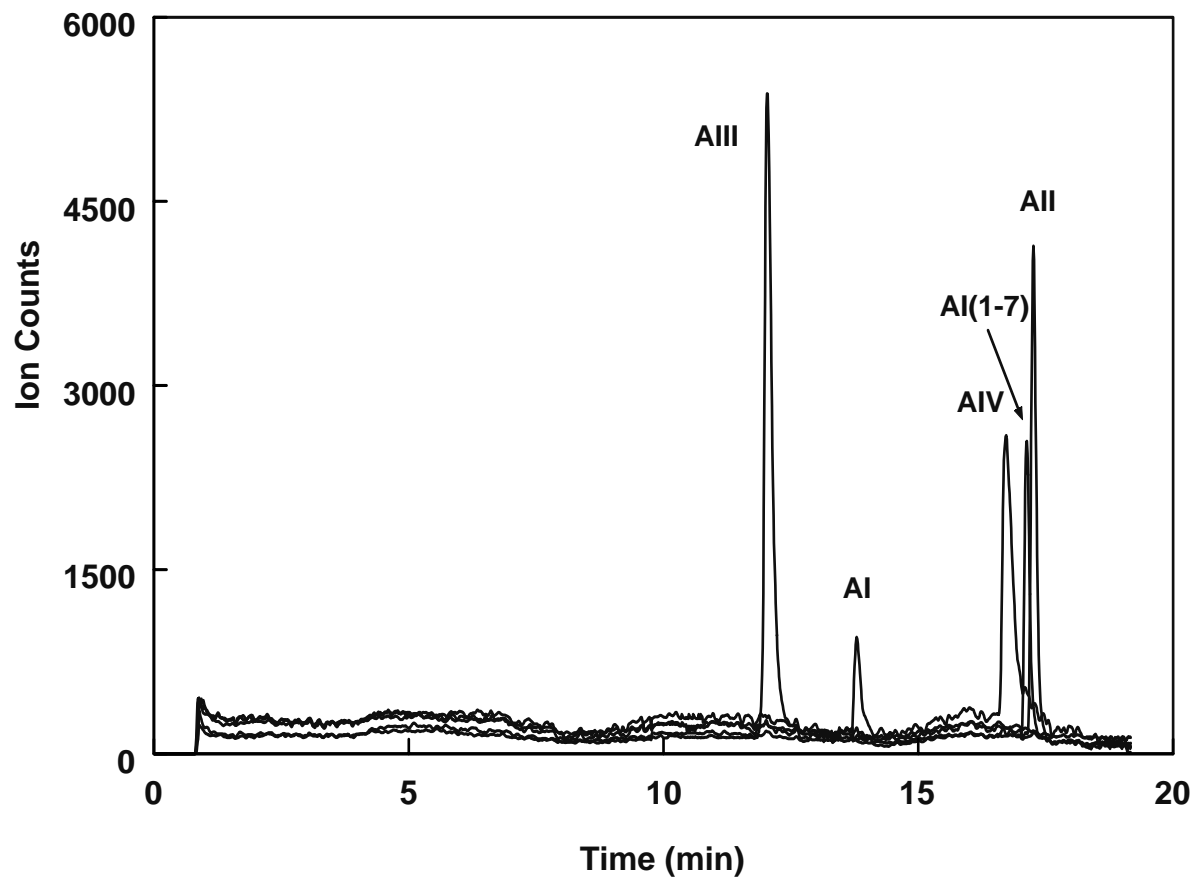

Figure V.7. FAI-CE-MS analysis of a 0.1 μM angiotensin mixture. Conditions: capillary, 65 cm PVA, 50 μm i.d., 360 μm o.d.; injection, 25 kV/5 min; run voltage, 30 kV; BGE, 12.5 mM ammonium acetate, pH 4.5; sample in 1.25 mM ammonium acetate; ESI voltage, 3300 V; liquid sheath, 70:30:0.2 methanol/water/formic acid, 2.0 $\mu\text{L}/\text{min}$.

When the formic acid in the liquid sheath solution was replaced by acetic acid, all the angiotensins were baseline resolved in both ITP-CE and FAI-CE (see Figures V.8 and V.9). It is noteworthy that while the type of acid in the liquid sheath did not significantly affect the CE separation, it had a pronounced influence on the separation in both ITP-CE and FAI-CE. This is most likely due to the fact that the capillary length available for CE separation is longer with simple CE-MS than with either FAI-CE or ITP-CE. Also, electric current is on in both FAI-CE and ITP-CE during the preconcentration step, which represents an additional time interval during which the liquid sheath counterions can enter the capillary and migrate toward the inlet. As discussed before, if the mobility of the liquid sheath counter ion differs from the mobility of the separation buffer counter ion, a moving ionic boundary results which can alter the electrophoretic separation. This is most likely the underlying cause of the incomplete separation when using formic acid in the liquid sheath.

The potential for signal enhancement of the developed methods can be easily seen by comparing the CE-MS separation of a 1 μ M angiotensin sample (Figure V.10), with FAI-CE-MS analysis of a 10-nM angiotensin mixture injected at 30 kV for 10 min (Figure V.11), and the results of ITP-CE-MS with \sim 30% of the capillary volume filled with the 100 nM angiotensin mixture (Figure V.12). The detection limits were below 10 nM, except for AI (17 nM), for FAI-CE-TOFMS, and below 30 nM for ITP-CE-MS, except for AI which had LOD \sim 70 nM.

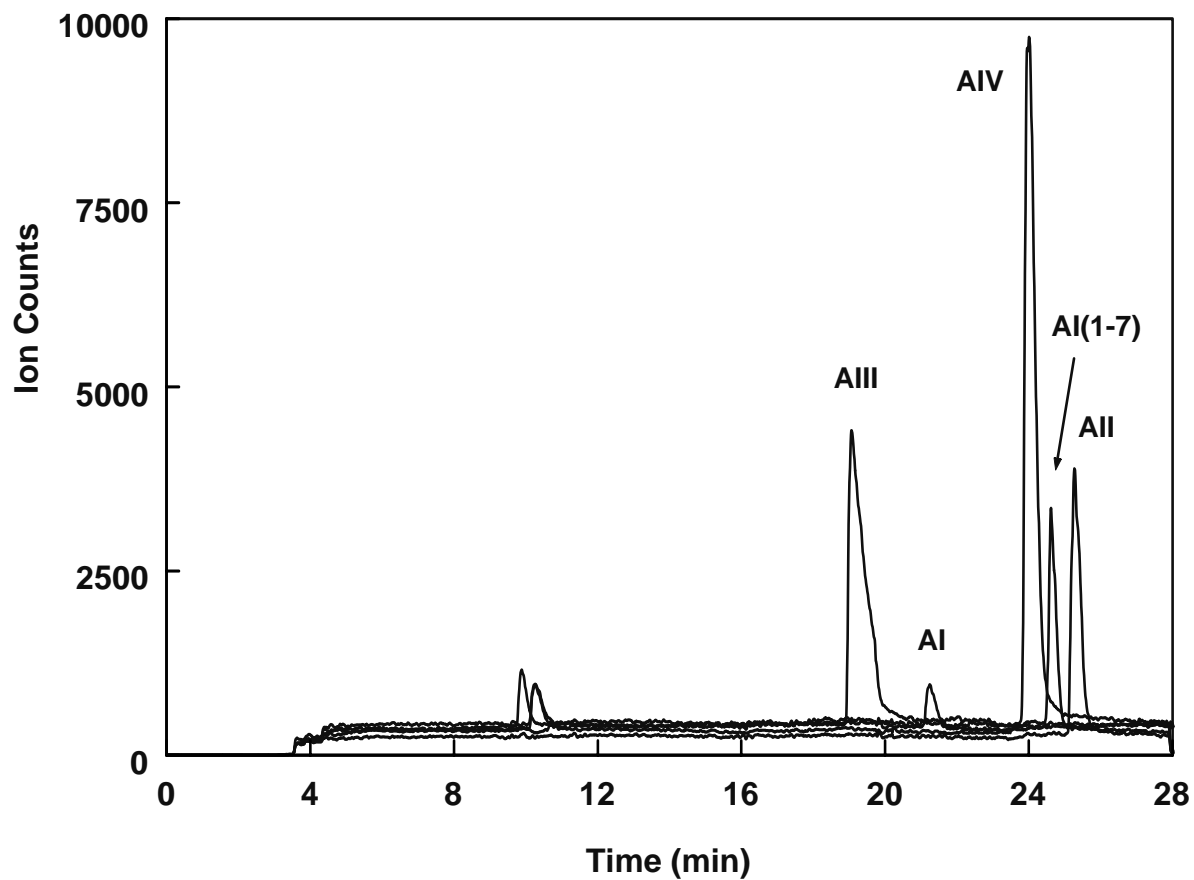

Figure V.8. ITP-CE-MS analysis of a 1 μ M angiotensin mixture. Conditions: capillary, 80 cm PVA, 50 μ m i.d., 360 μ m o.d.; injection, 100 mbar/3 min (~30% fill); ITP focusing, 20 kV/3.5 min; CE voltage, 30 kV; LE/BGE, 12.5 mM ammonium acetate, pH 4.5; TE, 10 mM acetic acid; sample in 5 mM acetic acid. ESI voltage, 3300 V; liquid sheath, 70:30:0.2 methanol/water/acetic acid, 1.7 μ L/min.

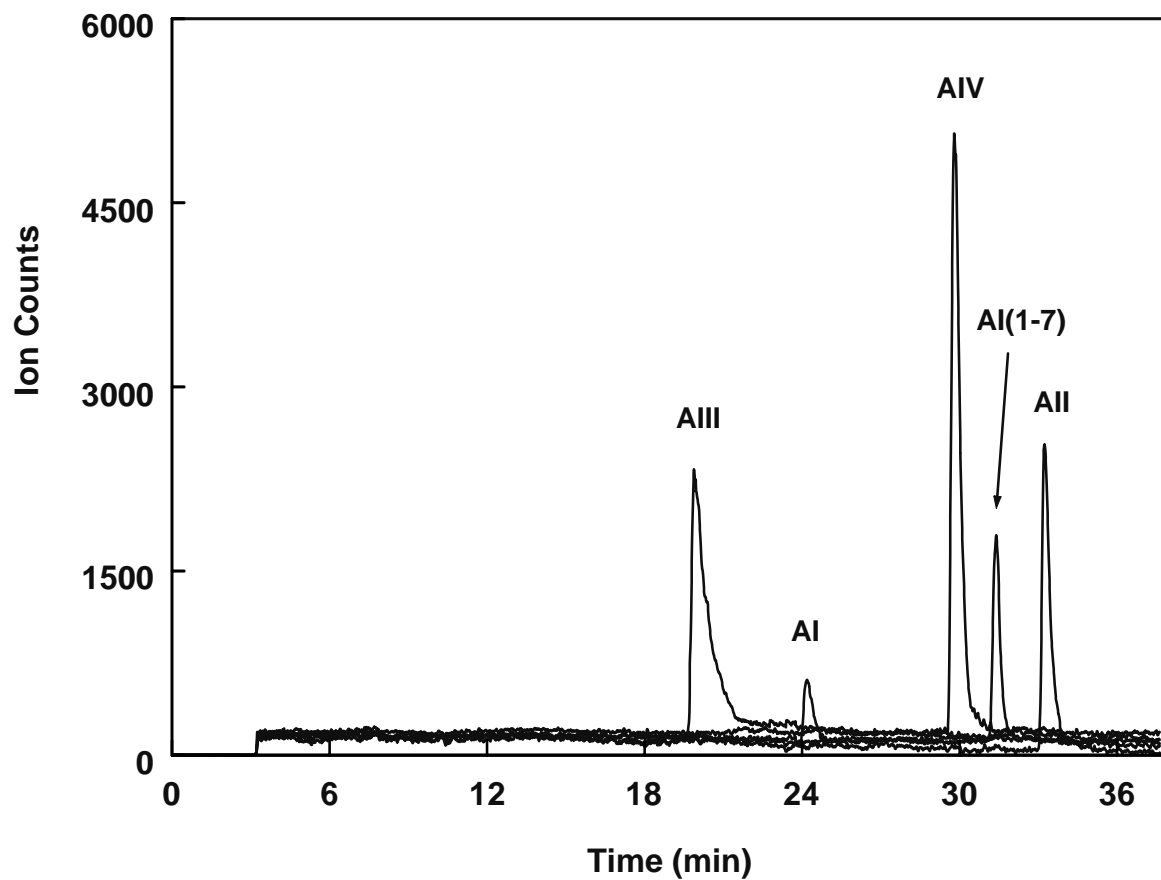

Figure V.9. FAI-CE-MS analysis of a 0.1 μM angiotensin mixture. Conditions: capillary, 80 cm PVA, 50 μm i.d., 360 μm o.d., sharpened outlet end; injection, 30 kV/5 min; CE voltage, 30 kV; BGE, 12.5 mM ammonium acetate, pH 4.5; sample in 1.25 mM ammonium acetate; ESI voltage, 3150 V; liquid sheath, 70:30:0.2 methanol/water/acetic acid, 1.5 $\mu\text{L}/\text{min}$.

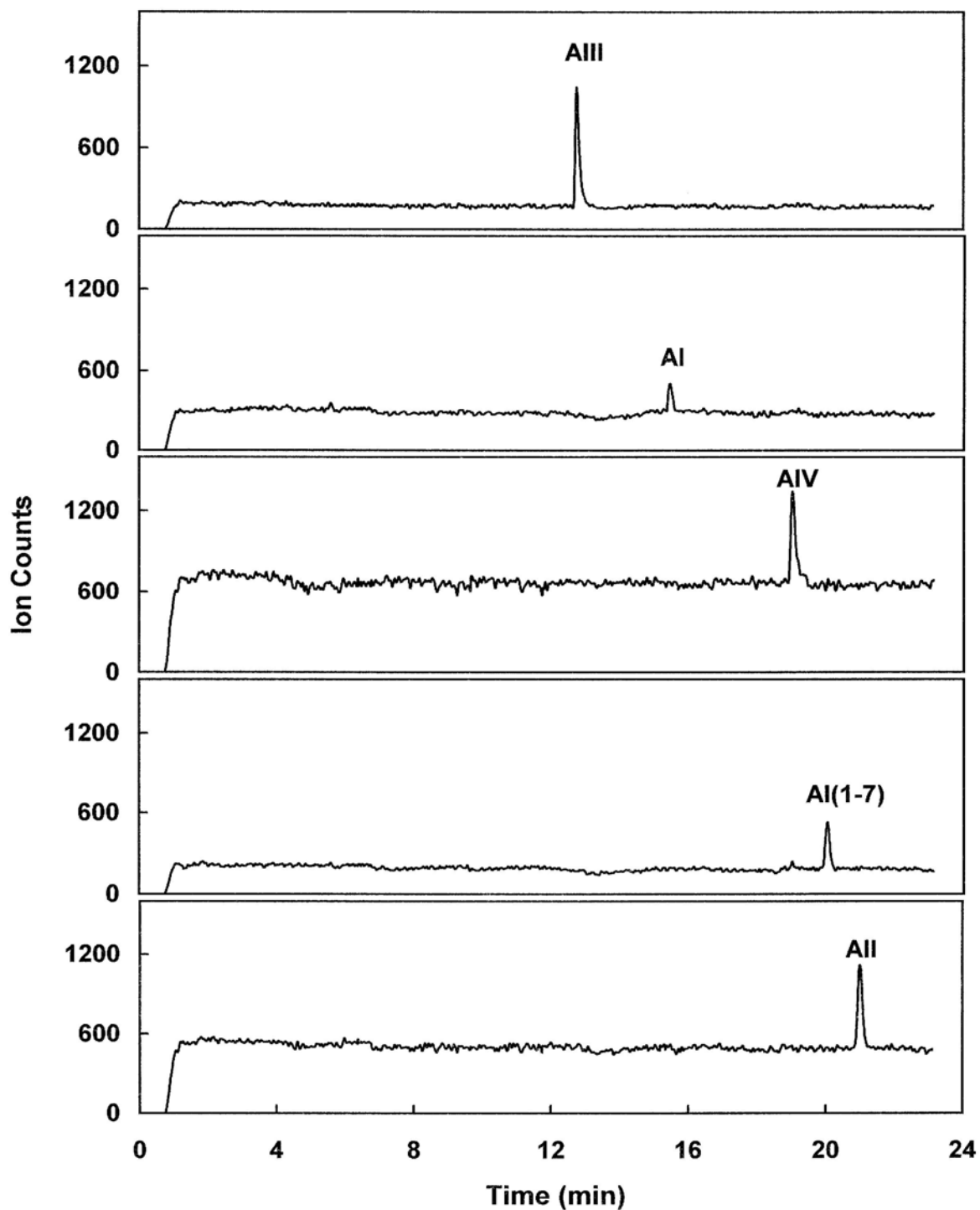

Figure V.10. CE-MS analysis of a 1 μ M angiotensin mixture. Conditions: capillary, 65 cm PVA, 50 μ m i.d., 360 μ m o.d. sharpened outlet end; injection, 100 mbar/0.24 min; run voltage, 30 kV; BGE, 12.5 mM ammonium acetate, pH 4.5; ESI voltage, 3330 V; liquid sheath, 70:30:0.2 methanol/water/acetic acid, 2.0 μ L/min.

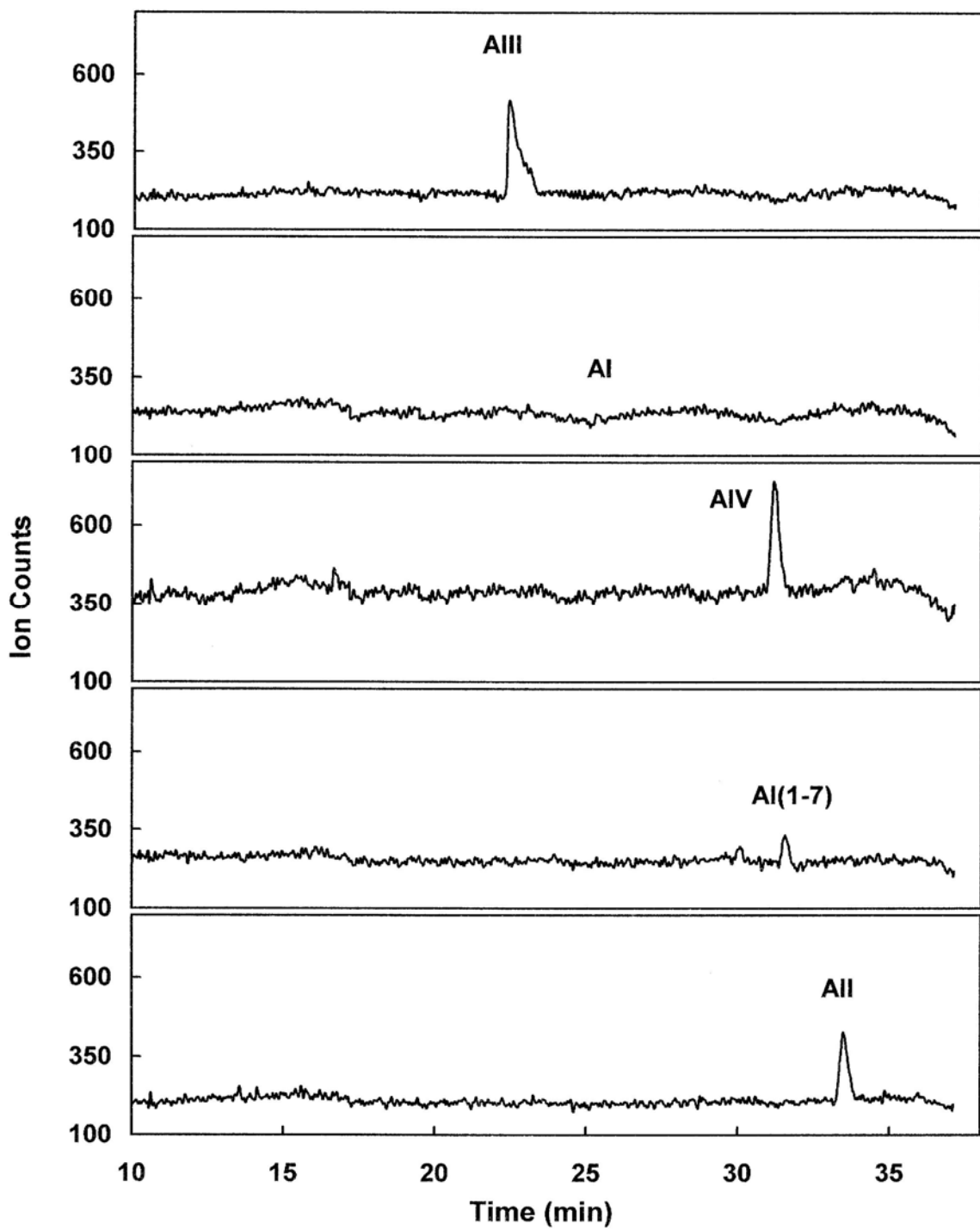

Figure V.11. FAI-CE-MS analysis of a 10 nM angiotensin mixture. Conditions: same as in Figure V.21.

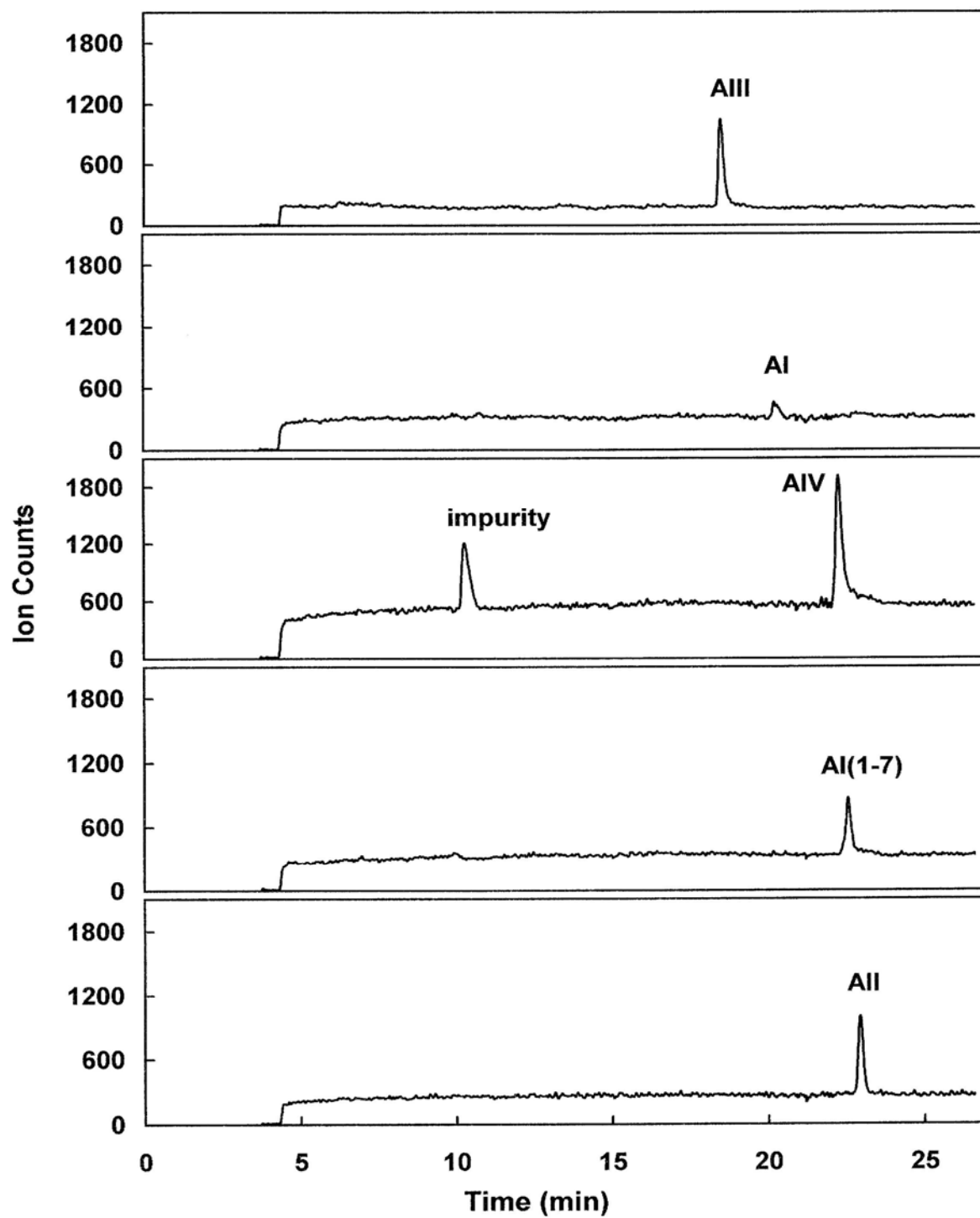

Figure V.12. ITP-CE-MS analysis of a 0.1 μM angiotensin mixture. Conditions: same as in Figure V.22.

V.3.7. Comprehensive ITP-CE-TOFMS

The details of the comprehensive ITP-CE system coupled with UV detection developed in this laboratory have been reported elsewhere [48,49]. We attempted to further improve this technique by replacing the generally non-specific UV detector with the highly specific TOFMS.

In our arrangement, the ITP column had an internal diameter that was larger (200 μm i.d.) than the outer diameter of the CE column (187 μm i.d.). The larger i.d. of the ITP column was to allow for a larger sample volume to be introduced for analysis. The injected sample volume (up to 10 μL in this study) was first concentrated and separated in the ITP column. The ITP zones were then allowed to migrate just past the inlet end of the CE column, thereby allowing some sample to enter the column. Using a counterflow of LE, the remaining analytes, which were not moved onto the CE column, were pushed back into the ITP column, where they continued to focus and migrate once again towards the CE column. This refocusing occurred at the same time as the sample introduced into the CE column was separated, since the focusing/separation voltage was on continuously. The buffer infused at the bifurcation point at the junction of the ITP and CE columns acted as both background electrolyte in CE and as LE in ITP. These multiple injections were repeated until the whole sample was analyzed. The total analysis time varied depending on the concentration of the sample. Samples with higher analyte concentrations required a greater number of CE injections and subsequent refocusing steps, leading to longer analysis times. For quantitation purposes, the results of the multiple CE injections can be added together to provide a summed electropherogram as shown by Chen [48] and Bowerbank [49].

One of the differences between ITP-CE-UV and ITP-CE-TOFMS was that with UV detection, a window was placed on-column by removing a small portion of the polyimide coating, and a buffer reservoir was placed at the end of the column to serve as ground to complete the circuit. This buffer vial also produced a “closed” system whereby hydrodynamic flow was suppressed inside the CE capillary when the LE counterflow was initiated at the bifurcation point. When using TOFMS as the detector, an electrospray could be established at the end of the CE column, leaving it open to the atmosphere. In all separations with ITP-CE-TOFMS, some peak tailing was observed. This can be attributed to the presence of hydrodynamic flow induced by the LE counterflow. Although not evaluated in this study, either the coupling of an ITP column with a larger i.d. or the use of a CE column with a smaller i.d. would favor the ITP column as the path of least resistance for the LE counterflow and should decrease the flow inside the CE capillary.

V.3.7.1. Analysis of a high concentration sample by comprehensive ITP-CE-TOFMS

This hyphenated separation-detector system was employed for the study of the angiotensins. Ten microliters of an angiotensin mixture (30 μ M each analyte) was introduced into the ITP capillary. After initial 30-min ITP focusing time, the voltage was lowered from 24 kV to 10 kV. The formed ITP zones were monitored via a UV detector placed at the bifurcation point. A small portion of the zones was allowed to migrate into the CE capillary and the rest of the zones were pushed back into the ITP capillary by injecting 4 μ L of leading electrolyte at 60 μ L/min. The zones, distorted by the injection of LE, were allowed to refocus for ~10 min in the ITP capillary and were again allowed to

enter the CE capillary. This process was repeated until the whole ITP stack was analyzed by CE. A representative ITP-CE-TOFMS analysis of a 30 μM angiotensin sample is shown in Figure V.13. In this case, fourteen injections from the focused ITP stack into the CE capillary were performed. Time zero on the time axis corresponds to the first injection from the ITP into the CE capillary. The first peak appeared in approximately 3 min. Peaks resulting from subsequent injections eluted from the CE capillary in ~ 10 min intervals. Each window represents the m/z trace of one particular angiotensin.

While the ITP electropherogram in Figure V.4A is characterized by flat-top zones, ITP-CE separation in Figure V.13 produced more recognizable CE peaks. However, some of the analyte peaks (AI (1-7) and AII) in Figure V.13 were broader than expected. One explanation for this finding is that, as a consequence of manually controlling the injection time, there is a possibility that the ITP stack migrates too far past the front of the CE capillary, thus allowing some TE to enter the CE capillary along with the analytes. Since LE was infused behind the sample plug at the bifurcation point, the LE (having a higher electrophoretic mobility) raced through the sample to the front of the plug, resulting in the separation of AIII, AI and AIV (when present). However, it appears that due to the presence of a small volume of TE at the end of the stack, and due to the short length of the CE capillary, the transition of the last two ITP zones into CE peaks (AI(1-7) and AII) might not have been complete. This problem should be solved by increasing the length of the CE capillary and/or using computer control of the injection time based on a signal from the detector monitoring the analyte position in the ITP capillary. Such an automated design has not yet been developed.

In this set of experiments, when a more concentrated sample containing only major components was used, multiple successive injections were required to analyze the entire sample. As shown in Figure V.4A, the same sample was separated in one relatively short run using ITP-TOFMS alone. Therefore, it would seem advantageous to use ITP-TOFMS instead of comprehensive ITP-CE-TOFMS for the analysis of more concentrated samples. However, many clinical specimens are complex, consisting of components differing greatly in concentration. Often, it might be desirable to measure analytes present at trace levels together with other, more abundant compounds. While ITP-TOFMS alone would adequately detect and quantitate the major components, the signal of the trace analytes, represented by sharp peaks or mixed zones between adjacent flat-top zones, could be either suppressed or difficult to quantitate. Although not fully investigated in this study, ITP-CE-TOFMS is believed to be a valuable tool for such applications.

V.3.7.2. Analysis of a low concentration sample by comprehensive ITP-CE-TOFMS

Figure V.14 represents an ITP-CE-TOFMS analysis of a low concentration angiotensin sample. The settings in Figure V.14 were identical to those for Figure V.13. The concentrations of analytes in Figure V.14 were 0.3 μM for AIV, 3 μM for AIII, 5 μM for AI and AI (1-7), and 8 μM for AII. AIV was purposely added at a concentration 10-30 fold lower than the rest of the analytes to demonstrate the capability of the ITP-CE technique to separate trace compounds from more concentrated analytes. The whole sample zone (concentrated in the ITP capillary) could be analyzed using two consecutive

injections into the CE capillary. The first peak in each selected-ion plot results from the first injection, the second peak from the second injection.

As stated above, detection of ITP zones in samples containing analytes present in amounts insufficient to form discrete flat-top zones was difficult due to ion suppression and discrimination that occurred within the narrow mixed zones (see Figures V.4A and V.4B). However, Figure V.14 demonstrates that when CE was added as a second dimension of separation, the detection problems of mixed ITP zones were resolved. Each component of the sample preconcentrated by ITP was detected as a separate CE peak.

Similar to coupling of the single-column preconcentration techniques to the mass spectrometer, the detection limits obtained with comprehensive ITP-CE coupled to the TOFMS were not as good as when a UV detector was used. As discussed in Chapter II, the decrease in sensitivity is partially due to using liquid sheath flow during electrospray ionization. Also, during this portion of the work, most of our effort was focused on the demonstration of proof of principle, with less effort to maximize the signal intensities by manipulating the MS settings.

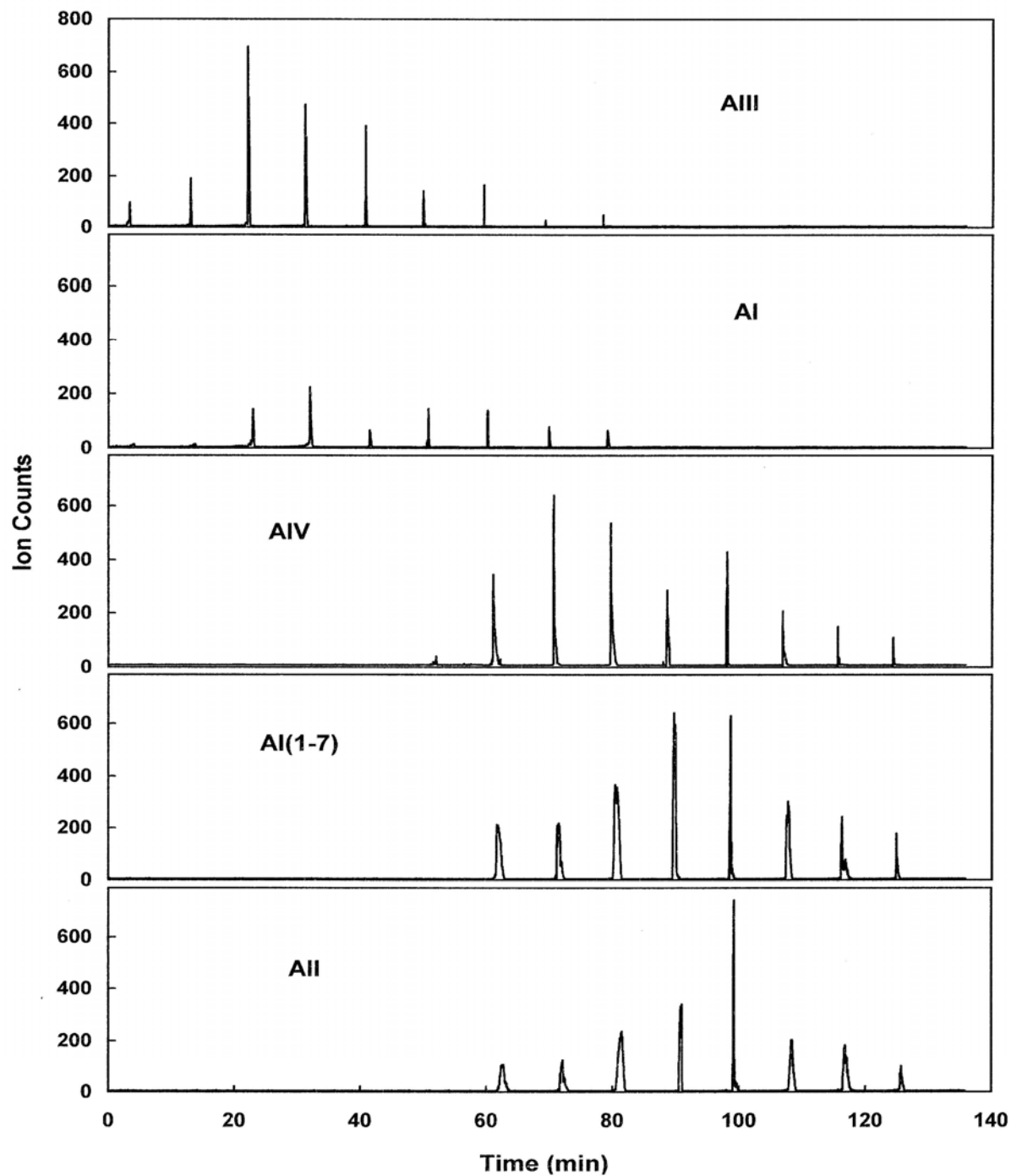

Figure V.13. Comprehensive ITP-CE-TOFMS of a high-concentration (30 μ M) mixture of angiotensins. Conditions: ITP column, 20 cm PVA, 200 μ m i.d., 365 μ m o.d., 15 cm effective separation length; with CE column, 20 cm PVA, 50 μ m i.d., 187 μ m o.d.; injection volume, 10 μ L; separation voltage, 24 kV for initial ITP, 10 kV for subsequent ITP and CE steps; LE/BGE, 10 mM triethylamine acetate, pH 4.5; TE, 10 mM acetic acid; LE counterflow, 4 μ L; infusion rate, 60 μ L/min; ESI voltage, 4 kV; interface plate temperature, 80 $^{\circ}$ C; liquid sheath, 70:30:0.1 methanol/water/acetic acid, 1.5 μ L/min.

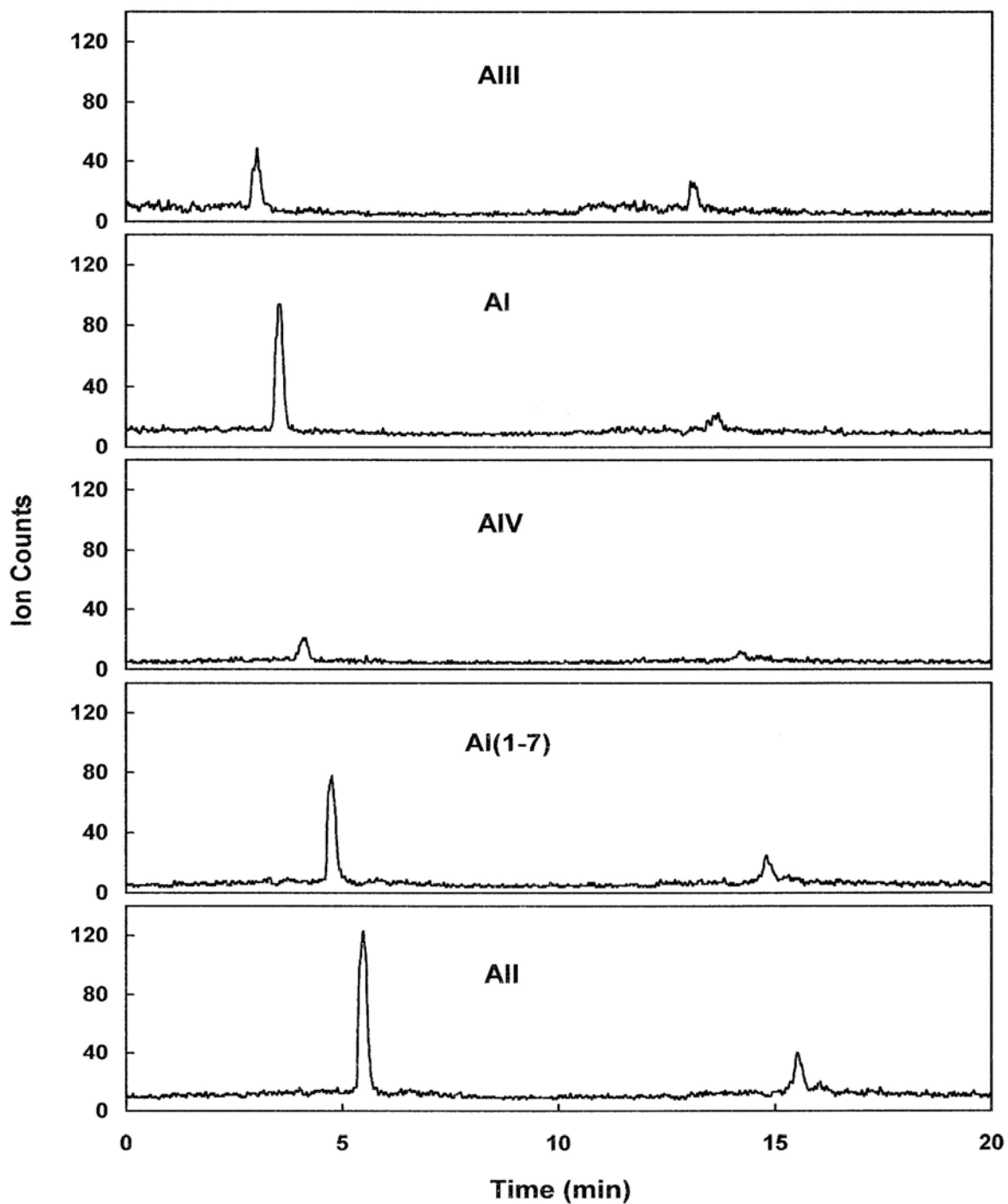

Figure V.14. Comprehensive ITP-CE-TOFMS of a low-concentration angiotensin mixture. Sample: 0.3 μM AIV, 3 μM AIII, 5 μM AI and I (1-7), and 8 μM AII. Conditions: same as in Figure V.13.

V.4. CONCLUSIONS

The sensitivity enhancement capabilities of electrophoretic preconcentration methods for CE analysis of angiotensin peptides were explored using UV detection. Subsequently, the developed methods were coupled successfully to a highly specific electrospray ionization TOFMS detector. It was shown, that while the high sample capacity ITP-TOFMS method can be used satisfactorily as a stand-alone separation technique for the analysis of samples with analyte levels sufficient for the formation of well-developed flat-top zones, at lower concentrations and with the same sample volume, the well-defined ITP zones collapsed into overlapping narrow, peak-shaped mixed zones. The detection of the sample components in such zones, otherwise very complicated or impossible with conventional UV or conductivity detectors, was made possible by the use of selected ion monitoring capability of the TOFMS. However, in some cases, ion suppression and discrimination occurred and made quantitative analysis of narrow mixed ITP highly problematic.

These difficulties were overcome by coupling ITP, as a preconcentration step, to CE separation. This allowed all analytes in the low-concentration samples to be readily separated and detected as distinct CE peaks. In this two-dimensional analysis, ion suppression was avoided or at least significantly reduced, which makes quantitation much more reliable. For single-column transient ITP-CE, when 30% of the capillary volume was filled with sample, the signal enhancement was about 10- to 20-fold greater than simple CE. The detection limits were ~10 nM using UV detection and below 30 nM (except for AI, the LOD of which was ~70 nM) using TOFMS detection. The comprehensive ITP-CE-TOFMS system was capable of performing multiple-injection CE

analyses of higher sample volumes without sacrificing any portion of the sample. The combination of large volume injection and high resolving power of comprehensive ITP-CE, together with the specificity of TOFMS detection, are very promising for the analysis of trace components mixed with major components in complex matrices.

Very low detection limits were obtained using field amplified injection as a sample preconcentration method. With UV detection, the angiotensins were detected at concentrations ~ 1 nM. Using TOFMS detection, the detection limits were below 10 nM, except for AI (17 nM). The limitation of this method compared to ITP is the discriminative character of the electrokinetic injection mode, which can be compensated for, e.g., by employing isotopically labeled standards.

The potential usefulness of these techniques was demonstrated using angiotensin standards. The next step will be to apply the developed methods to biological samples. Due to the adverse effects of high salt concentrations present in the sample on both electrophoretic separations and ESI-TOFMS detection, it will be necessary to perform a thorough sample workup aimed at substantially reducing the amount of salts in the sample as well as eliminating other potential interferences such as proteins. This can be accomplished using solid phase extraction, which also often serves as an additional preconcentration step. Concentration factors are frequently 10 to 50. Reversed phase bonded silica sorbents have often been used for the extraction of peptides from biological matrices. Combining the SPE sample workup with the above sensitivity enhancement methods should make it possible to use the developed methodology for the analysis of pathological levels of angiotensins.

V.5. REFERENCES

- [1] E.G. Biglieri, J.D. Baxter, in P. Felig, J.D. Baxter, A.E. Broadus, L.A. Frohman (Eds.), *Endocrinology and Metabolism*, McGraw Hill, Inc., New York, 1981, Ch.14.
- [2] S. Saltman, A. Baukal, S. Water, F.M. Bumpus, K.J. Catt, *Endocrinology*, 97 (1975) 275.
- [3] B.G. Zimmerman, *Fed. Proc., Fed. Am. Soc. Exp. Biol.*, 37 (1978) 199.
- [4] R.T. Peaston, T.W.J. Lennard, L.C. Lai, *J. Clin. Endocrin. Met.* 81 (1996) 1378.
- [5] M. Hanssens, M.J.N.C. Keirse, P.J. Lijnen, M.-J. Kucharski, C. Luyten, F.A. Van Assche, *J. Biochem. Biophys. Methods*, 21 (1990) 103.
- [6] G.O.A. Naik, G.W. Moe, *J. Chromatogr. A* 870 (2000) 349.
- [7] B.J. Ledwith, M.K. Cahill, L.S. Losse, S. M. Satiritz, R.S. Eydelloth, A.L. Dallob, W.K. Tanaka, S.M. Galloway, W.W. Nichols, *Anal. Biochem.* 213 (1993) 349.
- [8] K. Hermann, D. Ganten, T. Unger, C. Bayer, R.E. Lang, *Clin. Chem.* 34 (1988) 1046.
- [9] Q.C. Meng, J. Durand, Y.-F. Chen, S. Oparil, *J. Chromatogr.* 614 (1993) 19.
- [10] T. Matsui, K. Tamaya, T. Kawasaki, Y. Osajima, *J. Chromatogr. B* 729 (1999) 89.
- [11] V.F. Fredline, E.M. Kovacs, P.J. Taylor, A.G. Johnson, *Clin. Chem.* 45:5 (1999) 659.
- [12] H.J. Isaaq, *Electrophoresis* 21 (2000) 1921.
- [13] S.N. Krylov, N.J. Dovichi, *Anal. Chem.* 72 (2000) 111R.
- [14] N.A. Guzman, *LCGC* 17 (1999) 16.
- [15] G. Hempel, *Electrophoresis* 21 (2000) 691.

- [16] T. Stroink, E. Paarlberg, J.C.M. Waterval, A. Bult, W.J.M. Underberg, *Electrophoresis* 22 (2001) 2374.
- [17] M. Albin, P.D. Grossman, S.E. Moring, *Anal. Chem.* 56 (1993) 489A.
- [18] R.-L. Chien, D.S. Burgi, *Anal. Chem.* 64 (1992) 489A.
- [19] Ch.-X. Zhang, W. Thormann, *Anal. Chem.* 68 (1996) 2523.
- [20] S. Locke, D. Figeys, *Anal. Chem.* 72 (2000) 2684.
- [21] C.-X. Zhang, Y. Aebi, W. Thormann, *Clin. Chem.* 42 (1996) 1805.
- [22] C.-X. Zhang, W. Thormann, *Anal. Chem.* 70 (1998) 540.
- [23] F.M. Everaerts, J.L. Beckers, T. P.E.M. Verheggen, *Isotachopheresis: Theory, Instrumentation and Applications, Journal of Chromatography Library Vol.6*, Elsevier, Amsterdam, 1976, Ch. 2.
- [24] F. Kvasnička, M. Jaroš, B. Gaš, *J. Chromatogr.* 916 (2001) 131.
- [25] F. I. Onuska, D. Kaniansky, K.D. Onuska, M.L. Lee, *J. Microcol. Sep.* 10 (1998) 567.
- [26] J. Sádecká, A. Hercegová, J. Polonský, *J. Chromatogr. B* 729 (1999) 11.
- [27] J. Ježek, M. Šuhaj, *J. Chromatogr. A* 916 (2001) 185.
- [28] P. Gebauer, P. Boček, *Electrophoresis* 18 (1997) 2154.
- [29] J. Čáslavská, T. Kaufmann, P. Gebauer, W. Thormann, *J. Chromatogr.* 638 (1993) 205.
- [30] R.D. Smith, J.A. Loo, C.J. Barinaga, C.G. Egmonts, H.R. Udseth, *J. Chromatogr.* 480 (1989) 211.
- [31] Z.D. Peterson, D.C. Collins, C.R. Bowerbank, M.L. Lee, S.W. Graves, *J. Chromatogr. B* 776 (2002) 221.

- [32] J. L. Beckers, P. Boček, *Electrophoresis* 21 (2000) 2747.
- [33] Z.D. Peterson, C.R. Bowerbank, D.C. Collins, S.W. Graves, M.L. Lee, J. *Chromatogr. A* 992 (2003) 169.
- [34] S. Chen, M.L. Lee, *J. Microcol. Sep.* 10 (1998) 423.
- [35] I. Naygová, D. Kaniansky, *J. Chromatogr. A* 916 (2001) 191.
- [36] F. Foret, E. Szoko, B.L. Karger, *J. Chromatogr.* 608 (1992) 3.
- [37] T.J. Thompson, F. Foret, P. Vouros, B.L. Karger, *Anal. Chem.* 65 (1993) 900.
- [38] N.J. Reinhoud, U.R. Tjaden, J. van der Greef, *J. Chromatogr.* 641 (1993) 155.
- [39] N.J. Reinhoud, U.R. Tjaden, J. van der Greef, *J. Chromatogr.* 673 (1994) 239.
- [40] J.C.M. Waterwal, C.J.L. la Porte, R. van't Hof, J. Teeuwsen, A. Bult, H. Lingeman, W.J.M. Underberg, *Electrophoresis* 19 (1998) 3171.
- [41] J.C.M. Waterwal, H. Krabbe, J. Teeuwsen, A. Bult, H. Lingeman, W.J.M. Underberg, *Electrophoresis* 20 (1999) 2909.
- [42] J. Gysler, M. Mazereeuw, B. Helk, M. Heitzmann, U. Jaehde, W. Shunack, U.R. Tjaden, J. van der Greef, *J. Chromatogr. A* 841 (1999) 63.
- [43] M. Larsson, E.S.M. Lutz, *Electrophoresis* 21 (2000) 2859.
- [44] D.S. Stegehuis, U.R. Tjaden, J. van der Greef, *J. Chromatogr.* 591 (1992) 341.
- [45] T. Hirokawa, A. Ohmori, Y. Kiso, *J. Chromatogr.* 634 (1993) 101.
- [46] M. Mazereeuw, U.R. Tjaden, J. van der Greef, *J. Chromatogr. A* 677 (1994) 151.
- [47] R.-L. Chien, D.S. Burgi, *Anal. Chem.* 64 (1992) 1046.
- [48] S. Chen, M.L. Lee, *Anal. Chem.* 72 (2000) 816.
- [49] C. R. Bowerbank, M.L. Lee, *J. Microcol. Sep.* 13 (2001) 361.
- [50] M.A. Strausbauch, J.P. Landers, P.J. Wettstein, *Anal. Chem.* 68 (1996) 306.

- [51] M.J. Baars, G. Patonay, *Anal. Chem.* 71 (1999) 667.
- [52] B.C. Lim, M.K. Sim, *J. Chromatogr. B* 655 (1994) 127.
- [53] I.M. Lazar, E.D. Lee, A.L. Rockwood, M.L. Lee, *J. Chromatogr. A* 791 (1997) 269.
- [54] K.C. Chan, G.M. Muschik, H.J. Isaaq, *J. Chromatogr. A* 718 (1995) 203.
- [55] D.S. Burgi, R.-L. Chien, *Anal. Chem.* 63 (1991) 2042.
- [56] J. Bergmann, U. Jaehde, W. Schunack, *Electrophoresis* 19 (1998), 305.
- [57] A.M. Enlund, D. Westerlund, *Chromatographia* 46 (1997) 315.
- [58] S. Chen, S.W. Graves, M.L. Lee, *J. Microcolumn Separations*, 11 (1999) 341.

CHAPTER VI

RECOMMENDATIONS FOR FUTURE RESEARCH

VI.1. RECOMMENDATIONS FOR FUTURE RESEARCH

Mass spectrometry has become a powerful tool in analytical chemistry, biochemistry, and related disciplines. It has been successfully coupled with many separation modes for the analyses of a diverse array of analytes in a variety of matrices, including biological, pharmaceutical and environmental samples. The specificity of detection using a mass spectrometer is unsurpassed by other detectors. However, the detection sensitivity is still an issue. While higher signal sensitivities have been achieved utilizing sheathless microspray or nanospray modes of electrospray ionization [1-3], the reproducibility, robustness, and flexibility of such designs are still problematic. Conversely, the liquid sheath interface, while offering higher reproducibility, robustness, and flexibility, usually produces detection limits that are comparable or even higher than those routinely obtained with UV detection. For separation methods coupled to MS, this lack of sensitivity can be compensated for by employing signal enhancement strategies based on increasing the amount of analyte loaded onto the separation column. However, as in the case of the angiotensins and other biomarkers present in the body at very low concentrations, additional signal enhancement is often necessary.

In this work, I used a basic design of the liquid sheath ESI interface, without any sensitivity enhancement. In order to develop separation methods that can be applied in clinical practice, one area that could benefit from further development would be the ESI

interface. Several modifications have been reported in the literature [4-12]. More sophisticated designs employing gas nebulization to assist the ionization process have been used to increase the quantity of desolvated ions entering the mass spectrometer [4-7]. Improvements in sensitivity can be also achieved by lowering the liquid sheath flow rate [8]. However, at lower flow rates, the signal stability has a tendency to decrease, and therefore, more expensive pumps allowing for a smoother delivery of the sheath liquid would need to be used.

In recent years, considerable effort has been devoted to increasing the ion transmission efficiency from the electrospray interface to the mass spectrometer. While the ionization efficiency of the electrospray is very high (50 - 100%), the transmission efficiency between the ESI source and the extraction region of the mass spectrometer is usually only a fraction of a percent (0.01 – 0.1%). Several designs have been developed in an effort to increase the number of ions that actually enter the detection region of the mass spectrometer. Shaffer et al. [9] reported a more than one order of magnitude increase in signal sensitivity with a newly developed rf ion funnel placed in the first vacuum stage of the mass spectrometer. This device can focus the expanding ion cloud more effectively and transmit it as a collimated ion beam from the sampling nozzle orifice to the skimmer. This design was further improved upon by the same group after implementing a heated multicapillary inlet for more efficient desolvation of the ESI spray [10] and later also a jet disruptor, which further increased the ion transmission [11]. Recently, Zhou et al. [12] developed a device for focusing ions at atmospheric pressure based on an industrial air amplifier employing Venturi and Coanda effects. They

achieved an ~18-fold increase in signal intensity and a 34-fold reduction in detection limits for reserpine.

Adjusting the MS voltage settings and the needle position in order to maximize the signal is usually a time consuming empirical process requiring a certain level of expertise. The development of an automated or semi-automated computer program capable of signal optimization, or at least of tracking the changes in voltages corresponding to changes in signal intensity, would greatly simplify the process of optimization of MS detection.

In clinical practice, assay reproducibility is of great importance. The reproducibility as well as efficiency of the electrospray ionization process depends greatly on the quality and reproducibility of the spray tips used. While improvements have been observed with tips sharpened by a diamond grit paper compared to straight-cut capillary ends, greater sensitivity and reproducibility can be accomplished with commercially available spray tips. Also advances in column coating technology and the commercial availability of inexpensive capillaries with the desired inner surface properties would aid in the improvement of assay-to-assay reproducibility. Employing the described advances in the ESI interface design and improvements in signal optimization and column coating technology should greatly improve assay sensitivity for trace clinical analysis.

VI.2. REFERENCES

- [1] J.F. Kelly, L. Ramaley, P. Thibault, *Anal. Chem.* 69 (1997) 51.
- [2] J.T. Whitt, M. Moini, *Anal. Chem.* 75 (2003) 2188.
- [3] G.M. Janini, T.P. Conrads, K.L. Wilkens, H.J. Isaaq, T.D. Veenstra, *Anal. Chem.* 75 (2003) 1615.
- [4] J.D. Henion, A.V. Mordehai, J. Cai, *Anal. Chem.* 66 (1994) 2103.
- [5] R.L. Sheppard, J. Henion, *Anal. Chem.* 69 (1997) 2901.
- [6] C. Siethoff, W. Nigge, M. Linscheid, *Anal. Chem.* 70 (1998) 1357.
- [7] S. Cherkaoui, J.-L. Veuthey, *Electrophoresis*, 23 (2002) 442.
- [8] R.D. Smith, J.H. Wahl, D.R. Goodlett, S.A. Hofstadler, *Anal. Chem.* 65 (1993) 574A.
- [9] S.A. Shaffer, D.C. Prior, G.A. Anderson, H.R. Udseth, R.D. Smith, *Anal. Chem.* 70 (1998) 4111.
- [10] T. Kim, H.R. Udseth, R.D. Smith, *Anal. Chem.* 72 (2000), 5014.
- [11] T. Kim, K. Tang, H.R. Udseth, R.D. Smith, *Anal. Chem.* 73 (2001), 4162.
- [12] L. Zhou, B. Yue, D.V. Dearden, E.D. Lee, A.L. Rockwood, M.L. Lee, *Anal. Chem.* 75 (2003), 5978.